

**MAYO**  
**POTATO WASHER**  
**MODEL 12000 SERIES**  
**OPERATOR'S MANUAL**

# **MAYO MANUFACTURING, INC. LIMITED WARRANTY**

THE FOLLOWING WARRANTIES FOR MACHINERY, EQUIPMENT OR PARTS SOLD BY MAYO MANUFACTURING, INC. ARE IN LIEU OF ALL OTHER WARRANTIES, EXPRESSED OR IMPLIED, OR THOSE WARRANTIES IMPOSED BY STATUE, INCLUDING, BUT NOT LIMITED TO ANY AND ALL IMPLIED WARRANTIES OR MERCHANTABILITY AND FITNESS FOR A PARTICULAR PURPOSE AND OF ANY AND ALL OTHER WARRANTY OBLIGATIONS ON THE PART OF MAYO MANUFACTURING, INC. (The Company).

The Company warrants the machinery, equipment or parts delivered against faulty workmanship or the use of parts delivered against faulty workmanship or the use of defective materials for a period of one (1) year from the date of shipment.

The Company's warranties set forth above are the only warranties made by the Company and shall not be enlarged, diminished or affected by, and no obligation or liability shall arise out of the Company's rendering technical or other advice or service in connection with the machinery, equipment or parts.

Parts or components furnished to the Company by third persons are guaranteed only to the extent of the original manufacturer's guarantee to the Company, a copy of which will be supplied to the Purchaser upon written request to the Company.

## **LIABILITY**

THE COMPANY'S SOLE AND EXCLUSIVE MAXIMUM LIABILITY, AND PURCHASER'S SOLE AND EXCLUSIVE REMEDY under the above warranty shall be, at the Company's option, the repair, or replacement of the machine, equipment or part which is found to be defective due to faulty workmanship or defective materials, and is returned by the Purchaser to the Company within the warranty period. Shipment both ways and in transit damage shall be at the purchaser's risk and expense. If the Company elects to repair or replace the machine, equipment, or part, the Company will have a reasonable time within which to do so.

The remedies set forth above are available upon the following conditions:

1. Purchaser has promptly notified Company upon discovery that the machinery, equipment, or parts are defective due to faulty workmanship or defective materials; and
2. Purchaser provides Company with a detailed description of the deficiencies; and
3. Company's examination discloses that the alleged deficiencies exist and were not caused by accident, fire, misuse, neglect, alteration, or any other hazard or by Purchaser's improper installation, use or maintenance.

Such repair or replacement shall constitute fulfillment of all Company's liability to Purchaser, whether based on contract or tort.

This warranty does not apply to any machine that has been altered outside the factory in any way so as, in the judgement of Mayo, to affect its operation, reliability or safety, or which has been subject to misuse, neglect or accident.

In the event the Company breach any other provisions of the Purchase Agreement, the Company's EXCLUSIVE MAXIMUM LIABILITY AND PURCHASER'S EXCLUSIVE REMEDY, whether in contract or tort, otherwise shall not in any event exceed the contract price for the particular machine, piece of equipment or parts involved.

IN NO EVENT SHALL COMPANY BE LIABLE TO ANYONE FOR SPECIAL, COLLATERAL, INCIDENTAL, OR CONSEQUENTIAL DAMAGES FOR BREACH OF ANY PROVISIONS OF THIS CONTRACT OR WARRANTY. SUCH EXCLUDE DAMAGES INCLUDE, BUT ARE NOT LIMITED TO, costs of REMOVAL AND REINSTALLATION OF ITEMS, Loss of GOODWILL, LOSS OF PROFITS, LOSS OF USE OR INTERRUPTION OF BUSINESS.

**WARRANTY VOID IF NOT REGISTERED**

**MAYO**  
**POTATO WASHER 12000 SERIES**

**WARRANTY REGISTRATION FORM & INSPECTION REPORT**

**WARRANTY REGISTRATION (please print)**

This form must be filled out by the dealer and signed by both the dealer and the customer at the time of delivery.

Customer's Name _____	Dealer Name _____
Address _____	Address _____
City, State/Province, Code _____	City, State/Province, Code _____
Phone Number ( ____ ) _____	Phone Number ( ____ ) _____
Contact Name _____	
Model _____	
Serial Number _____	
Delivery Date _____	

**DEALER INSPECTION REPORT**

- \_\_\_ Tire Pressure Checked and Wheel Bolts Torqued
- \_\_\_ Inspect Electrical System
- \_\_\_ Water Lines and Fittings Tight
- \_\_\_ Wash Nozzles Clean
- \_\_\_ Machine Lubricated
- \_\_\_ Conveyors Tensioned and Aligned
- \_\_\_ Drive Belts Aligned and operating Speed Set
- \_\_\_ Roller Chains Tensioned and Aligned
- \_\_\_ Speed Reducer Gearbox Oil Level Checked

**SAFETY**

- \_\_\_ All Safety Signs Installed
- \_\_\_ Lights, SMV Clean
- \_\_\_ Review Operating and Safety Instructions

I have thoroughly instructed the buyer on the above described equipment which review included the Operator's Manual content, equipment care, adjustments, safe operation and applicable warranty policy.

Date \_\_\_\_\_ Dealer's Rep. Signature \_\_\_\_\_

The above equipment and Operator's Manual have been received by me and I have been thoroughly instructed as to care, adjustments, safe operation and applicable warranty policy.

Date \_\_\_\_\_ Owner's Signature \_\_\_\_\_

WHITE	YELLOW	PINK
MAYO MFG., INC	DEALER	CUSTOMER

# TABLE OF CONTENTS

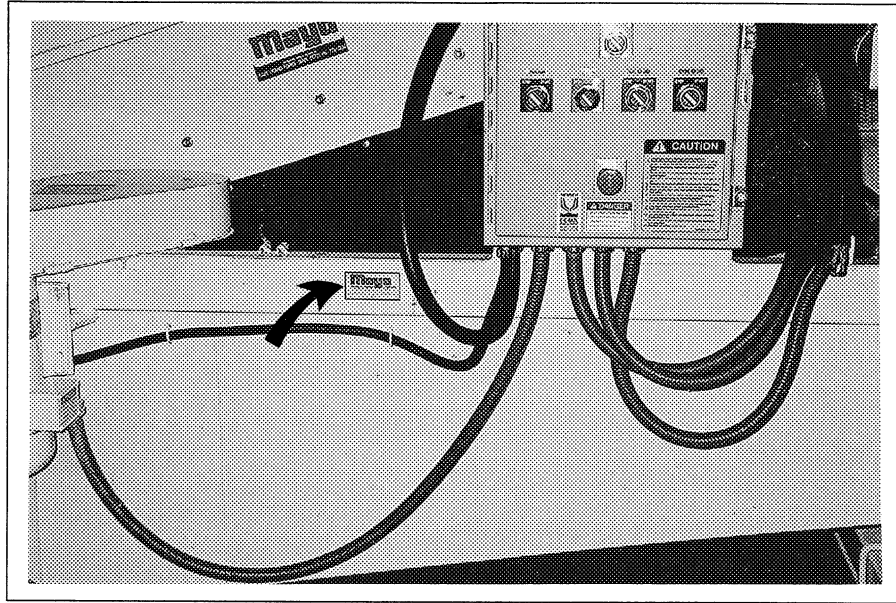
SECTION	DESCRIPTION	PAGE
<b>1</b>	<b>Introduction .....</b>	<b>1</b>
<b>2</b>	<b>Safety .....</b>	<b>2</b>
2.1	General Safety .....	3
2.2	Installation Safety .....	4
2.3	Operating Safety .....	4
2.4	Maintenance Safety .....	5
2.5	Electrical Safety .....	5
2.6	Tire Safety .....	5
2.7	Transport Safety .....	6
2.8	Storage Safety .....	6
2.9	Safety Signs .....	6
2.10	Employee Sign-Off Form .....	7
<b>3</b>	<b>Safety Sign Locations .....</b>	<b>8</b>
<b>4</b>	<b>Operation .....</b>	<b>12</b>
4.1	To the New Operator or Owner .....	12
4.2	Machine Components .....	13
4.3	General Operation Theory .....	14
4.4	Machine Break-In .....	15
4.5	Pre-Operation Checklist .....	15
4.6	Controls .....	16
4.6.1	Master OFF/ON .....	16
4.6.2	Trash Pump STOP/START .....	16
4.6.3	Elevator STOP/START .....	16
4.6.4	Brush Rollers STOP/START .....	16
4.6.5	Sponge Rollers STOP/START .....	16
4.6.6	Emergency STOP Control .....	16
4.7	Machine Preparation .....	17
4.8	Operating .....	19
4.8.1	Review and Follow Section 4.7 .....	19
4.8.2	Review and Follow Section 4.5 .....	19
4.8.3	Review and Follow Section 4.6 .....	19
4.8.4	Water Supply .....	19
4.8.5	Starting Washer .....	20
4.8.6	Stopping Machine .....	20
4.8.7	Emergency Stop .....	20
4.8.8	Auxiliary Equipment .....	21
4.8.9	Moving .....	21
4.8.10	Machine Speed .....	21
4.8.11	Nozzles .....	22
4.8.12	Rollers .....	23
4.8.13	Bruising .....	24
4.8.14	Water Quality .....	24
4.8.15	Operating Hints .....	24

SECTION	DESCRIPTION	PAGE
4.9	Transport .....	25
4.10	Storage .....	26
4.10.1	Placing In Storage .....	26
4.10.2	Removing From Storage .....	26
<b>5</b>	<b>Service and Maintenance .....</b>	<b>27</b>
5.1	Service .....	27
5.1.1	Fluids and Lubricants .....	27
5.1.2	Greasing .....	27
5.1.3	Servicing Intervals .....	28
5.1.4	Service Record .....	40
5.2	Maintenance .....	41
5.2.1	Electrical System Inspection .....	41
5.2.2	Electric Motor Restart .....	42
5.2.3	Speed Reducer Gearbox Oil .....	43
5.2.4	Breather Cleaning .....	44
5.2.5	Opt. Elevator Chain Tension/Alignment or Replacement .....	45
5.2.6	Roller Chain Drives .....	46
5.2.7	Trash Pump Belt Drive .....	48
5.2.8	Compression Roller Spacing .....	50
5.2.9	Roller Drives .....	51
5.2.10	System Speeds - Drive Belt .....	52
<b>6</b>	<b>Trouble Shooting .....</b>	<b>53</b>
<b>7</b>	<b>Specifications .....</b>	<b>54</b>
7.1	Mechanical .....	54
7.2	Bolt Torque .....	55
7.3	Electrical Schematic .....	56
<b>8</b>	<b>Index .....</b>	<b>57</b>

# SERIAL NUMBER LOCATION

Always give your dealer the serial number of your Mayo Potato Washer when ordering parts or requesting service or other information.

The serial number plate is located where indicated. Please mark the number in the space provided for easy reference.



**SERIAL NUMBER LOCATION**

**Model** \_\_\_\_\_

**Serial Number** \_\_\_\_\_

# 1 INTRODUCTION

Congratulations on your choice of a Mayo Model 12000 SERIES Potato Washer and welcome to Mayo's quality line of potato handling equipment. This equipment is designed and manufactured to meet the needs of a discriminating buyer in the agricultural industry for the loading and processing of harvest yields.

Safe, efficient and trouble free operation of your new Mayo Potato Washer requires that you, and anyone else who will be operating or maintaining the Washer, read, understand and practice ALL of the Safety, Operation, Maintenance and Trouble Shooting recommendations contained within this Operator's Manual.



This manual applies to most Model 12000 Series Potato Washers manufactured by Mayo. Certain options may be available to specifically tailor the Washer to your operation and may not be included in this manual. Please contact the manufacturer regarding additional information about these options. Use the Table of Contents and Index as a guide to find specific information.

Keep this manual handy for frequent reference and so that it will be passed on to new operators or owners. Call your Mayo dealer if you need assistance, information or additional copies of this manual.

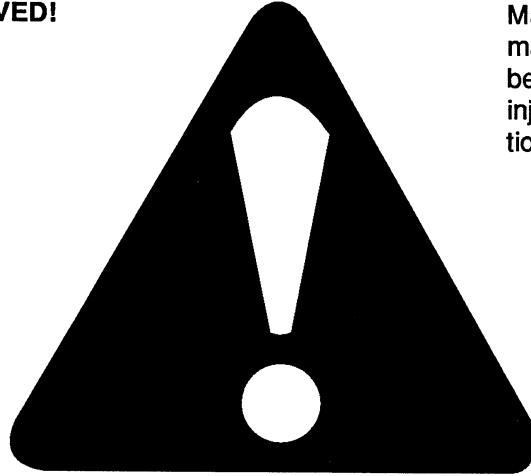
**MACHINE ORIENTATION** - The hopper end of the conveyor is the front. All controls are on the left side.

## 2 SAFETY

### SAFETY ALERT SYMBOL

This Safety Alert symbol means **ATTENTION! BECOME ALERT! YOUR SAFETY IS INVOLVED!**

The Safety Alert symbol identifies important safety messages on your Mayo Potato Washer and in the manual. When you see this symbol, be alert to the possibility of personal injury or death. Follow the instructions in the safety message.



Why is SAFETY important to you?

#### 3 Big Reasons

**Accidents Disable and Kill**  
**Accidents Cost You Money**  
**Accidents Can Be Avoided**

#### SIGNAL WORDS:

Note the use of the signal words **DANGER**, **WARNING** and **CAUTION** with the safety messages. The appropriate signal word for each message has been selected using the following guide-lines:

**DANGER** - Indicates an imminently hazardous situation that, if not avoided, will result in death or serious injury. This signal word is to be limited to the most extreme situations, typically for machine components that, for functional purposes, cannot be guarded.

**WARNING** - Indicates a potentially hazardous situation that, if not avoided, could result in death or serious injury, and includes hazards that are exposed when guards are removed. It may also be used to alert against unsafe practices.

**CAUTION** - Indicates a potentially hazardous situation that, if not avoided, may result in minor or moderate injury. It may also be used to alert against unsafe practices.



# SAFETY

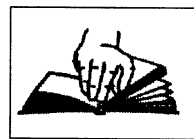
**YOU** are responsible for the **SAFE** operation and maintenance of your Mayo Potato Washer. **YOU** must ensure that you and anyone else who is going to operate, maintain or work around the Potato Washer be familiar with the operating and maintenance procedures and related **SAFETY** information contained in this manual. This manual will take you step-by-step through your working day and alerts you to all good safety practices while operating the Washer.

Remember, **YOU** are the key to safety. Good safety practices not only protect you but, also the people around you. Make these practices a working part of your safety program. Be certain that **EVERYONE** operating this machine is familiar with the procedures recommended and follows safety precautions. Remember, most accidents can be prevented. Do not risk injury or death by ignoring good safety practices.

- Potato Washer owners must give operating instructions to operators or employees before allowing them to operate the Washer, and at least annually thereafter.
- The most important safety device on this equipment is a **SAFE** operator. It is the operator's responsibility to read and understand **ALL** Safety and Operating instructions in the manual and to follow these. All accidents can be avoided.
- A person who has not read and understood all operating and safety instructions is not qualified to operate this machine. An untrained operator exposes himself and bystanders to possible serious injury or death.
- Do not modify the equipment in any way. Unauthorized modification may impair the function and/or safety and could affect the life of the equipment.
- Think **SAFETY!** Work **SAFELY!**

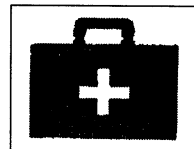
## 2.1 GENERAL SAFETY

1. Read and understand the Operator's Manual and all safety signs before supplying power, operating, maintaining or adjusting Washer.



2. Only trained, competent persons shall operate the Washer. An untrained operator is not qualified to operate this machine.

3. Provide a first-aid kit for use in case of an accident. Store in a highly visible place.



4. Provide a fire extinguisher for use in case of an accident. Store in a highly visible place.



5. Wear appropriate protective gear. This list includes but is not limited to:

- Protective shoes with slip resistant soles
- Protective glasses or goggles
- Heavy gloves
- Hearing protection



6. Turn machine OFF, shut down and lockout power supply, and wait for all moving parts to stop before servicing, adjusting, maintaining, repairing or cleaning. (Safety lockout devices are available through your Mayo dealer parts department).
7. Know the emergency medical center number for your area.
8. Review safety related items with all operators annually.

## **2.2 INSTALLATION SAFETY**

- 1. Disconnect and remove all mechanical locks, anchor chains and any other transport devices that would hinder or prohibit the normal functioning of the Washer upon start up. Serious damage to the machine and/or personal injury to the operator and bystanders may result from attempting to operate the machine while mechanical locking devices are still attached.**
- 2. Position the machine on firm, level ground before operating.**
- 3. Have at least one extra person available to assist when elevating, moving or connecting to other equipment.**
- 4. Make certain that sufficient amperage, at the proper voltage and frequency is available before connecting power. If you are uncertain, have a licensed electrician provide power to the machine.**
- 5. If using Washer as part of material handling system, anchor securely to other conveying equipment before starting.**

## **2.3 OPERATING SAFETY**

- 1. Read and understand the Operator's Manual and all safety signs before operating, maintaining, adjusting or repairing the Washer.**
- 2. Turn machine OFF, shut down and lock out power supply (safety lockout devices are available through your Mayo dealer parts department), and wait for all moving parts to stop before servicing, adjusting, maintaining or repairing.**
- 3. Install and properly secure all guards and shields before operating.**
- 4. Keep hands, feet, hair and clothing away from all moving parts.**
- 5. Clear the area of bystanders, especially small children, before starting.**
- 6. Make sure all control switches are in the off position before connecting power supply.**
- 7. Before supplying electrical power to the machine, be sure that you have adequate amperage at the proper phase and voltage to run it. If you do not know or are unsure, consult a licensed electrician.**
- 8. Keep the working area clean and dry.**
- 9. Review safety instructions annually.**

## 2.4 MAINTENANCE SAFETY

1. Read and understand all the information contained in the Operator's Manual regarding operating, servicing, adjusting, maintaining and repairing.
2. Turn machine OFF, shut down and lock out power supply (safety lockout devices are available through your Mayo dealer parts department), and wait for all moving parts to stop before servicing, adjusting, maintaining or repairing.
3. Follow good shop practices:

- Keep service area clean and dry.
- Be sure electrical outlets and tools are properly grounded.
- Use adequate light for the job at hand.



4. Make sure all guards and doors are in place and properly secured when operating the Washer.
5. Do not work on Washer electrical system unless the power cord is unplugged and the power supply is locked out.



## 2.5 ELECTRICAL SAFETY

1. Have only a qualified electrician supply power.
2. Make certain that the Washer is properly grounded at the power source.
3. Make certain that all electrical switches are in the OFF position before plugging the Washer in.
4. Turn machine OFF, shut down and lock out power supply (safety lockout devices are available through your Mayo dealer parts department), and wait for all moving parts to stop before servicing, adjusting, maintaining or repairing.
5. Disconnect power before resetting any motor or breaker overload.
6. Replace any damaged electrical plugs, cords, switches and components immediately.
7. Do not work on Washer electrical system unless the power cord is unplugged or the power supply is locked out.

## 2.6 TIRE SAFETY

1. Inflate tires to proper pressure as specified on the side wall of each tire. Do not overinflate or underinflate.
2. Failure to follow proper procedures when mounting a tire on a wheel or rim can produce an explosion which may result in serious injury or death.
3. Do not attempt to mount a tire unless you have the proper equipment and experience to do the job.
4. Have a qualified tire dealer or repair service perform required tire maintenance.

## 2.7 TRANSPORT SAFETY

1. Make certain that you are in compliance with local, state/provincial and federal regulations regarding transporting agricultural equipment on public roadways.
2. Make certain that all wheels and tires are in good repair and that tires are inflated to proper pressure. Do not underinflate or overinflate.
3. Make certain that all wheel bolts/lug nuts are tightened to proper torque specifications (refer to specification chart in Section 7.2).
4. Make certain that all mechanical locks and integral anchor chains are safely and positively connected before loading or transporting.
5. Raise and secure all jack stands.
6. Wrap up and bind to the frame all loose water line and electrical ends.
7. Be sure that any necessary SMV (slow moving vehicle) signs, reflectors and lights required by law are in proper place and are clearly visible to oncoming and overtaking traffic.
8. Be sure that the Washer is positively hitched to the towing vehicle. Use a proper safety chain to assure a safe hitch hook-up when transporting.
9. Adhere to local regulations regarding maximum weight, width and length.
10. Do not exceed 20 MPH (32 Km/H). Reduce speed on rough roads and surfaces.
11. Do not allow anyone to ride on the Washer or towing vehicle during transport.
12. Always use hazard flashers on the towing vehicle when transporting.

## 2.8 STORAGE SAFETY

1. Store the Washer on a firm level surface.
2. If required, make sure the unit is firmly blocked up.
3. Make certain that all mechanical locks are safely and positively connected before storing.
4. Store away from areas of human activity.
5. Do not allow children to play on or around the stored Washer.
6. Lock out power by turning off master control panel or junction box and padlocking the door shut to prevent electrocution or unauthorized start up of the Washer.

## 2.9 SAFETY SIGNS

1. Keep safety signs clean and legible at all times.
2. Replace safety signs that are missing or have become illegible.
3. Replaced parts that displayed a safety sign should also display the current sign.
4. Safety signs are available from your Distributor or the factory.

### How to Install Safety Signs:

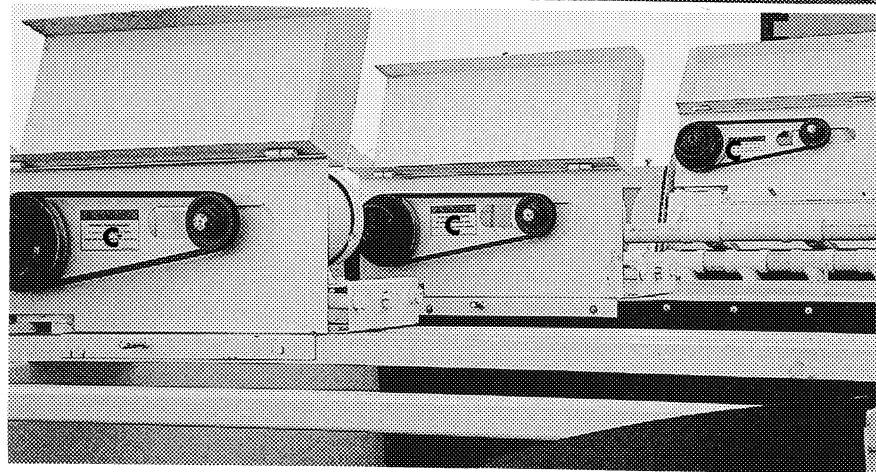
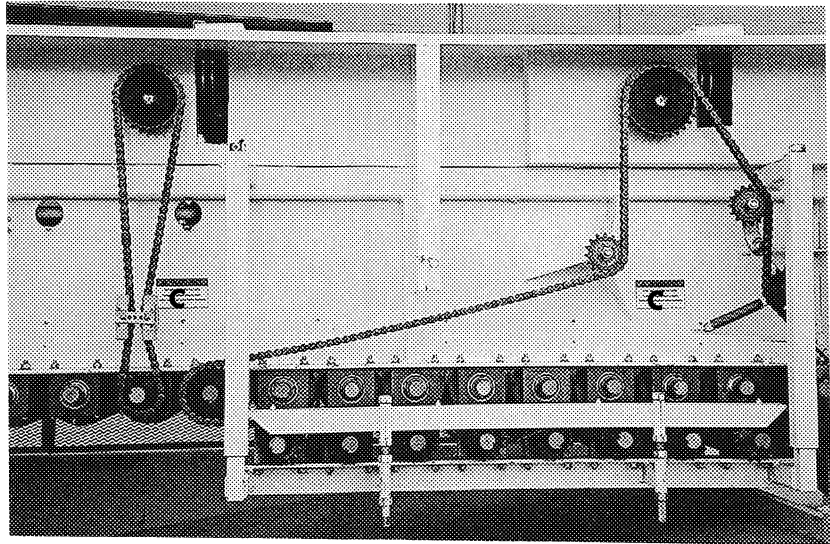
- Be sure that the installation area is clean and dry.
- Decide on the exact position before you remove the backing paper.
- Remove the smallest portion of the split backing paper.
- Align the sign over the specified area and carefully press the small portion with the exposed sticky backing in place.
- Slowly peel back the remaining paper and carefully smooth the remaining portion of the sign in place.
- Small air pockets can be pierced with a pin and smoothed out using the piece of sign backing paper.



### 3 SAFETY SIGN LOCATIONS

The types of safety signs and locations on the equipment are shown in the illustration below. Good safety requires that you familiarize yourself with the various safety signs, the type of warning and the area, or particular function related to that area, that requires your SAFETY AWARENESS.

- Think SAFETY! Work SAFELY!



**A**

**! WARNING**




**MOVING PART HAZARD**

To prevent serious injury or death from falling:

1. Do not stand or climb on machine when operating. Keep others off.
2. Keep hands away from moving parts.
3. Wear tight clothing and safety gear.

D-132

**B**

**! CAUTION**

1. Read Operator's Manual before starting.
2. Turn machine OFF, shut down and lock out power source, unplug power cord and wait for all moving parts to stop before servicing, adjusting, repairing or unplugging.
3. Keep all electrical components tight, dry and in good repair.
4. Keep all hydraulic components tight and in good repair.
5. Replace all worn or failed components immediately.
6. Install and secure all guards before operating.
7. Keep hands, feet, hair and clothing away from moving parts.
8. Install safety locks on the boom and elevator before transporting or working under them.
9. Lower boom and elevator to safety locks, center boom and install all safety locks before transporting.
10. Use pilot vehicles when transporting.
11. Stay away from overhead power lines and obstructions when moving. Electrocutation can occur without direct contact.
12. Do not stand or climb on machine when running. Keep others off.
13. Have only a qualified electrician provide power to the machine.
14. Review safety instructions annually.

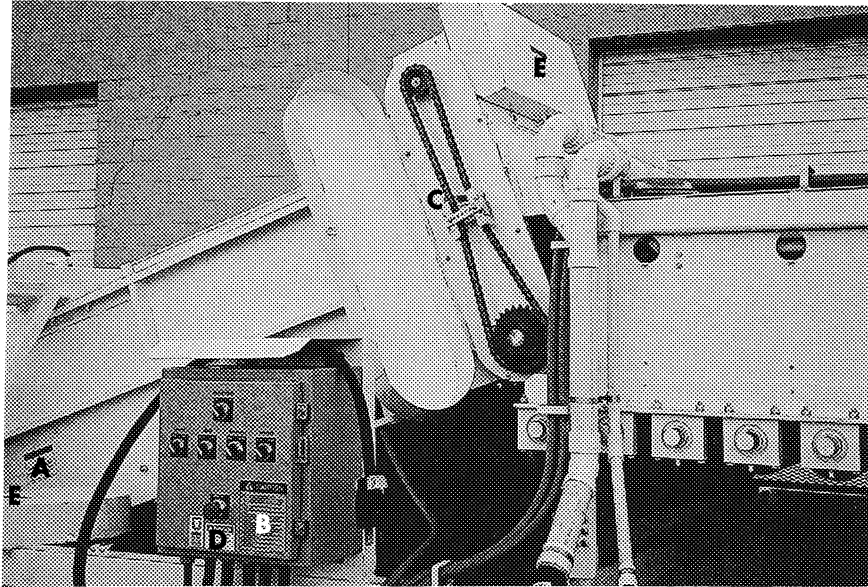
D-102

REMEMBER - If safety signs have been damaged, removed, become illegible or parts replaced without safety signs, new signs must be applied. New safety signs are available from your authorized dealer.

### 3 SAFETY SIGN LOCATIONS (cont'd)

The types of safety signs and locations on the equipment are shown in the illustration below. Good safety requires that you familiarize yourself with the various safety signs, the type of warning and the area, or particular function related to that area, that requires your SAFETY AWARENESS.

- Think SAFETY! Work SAFELY!

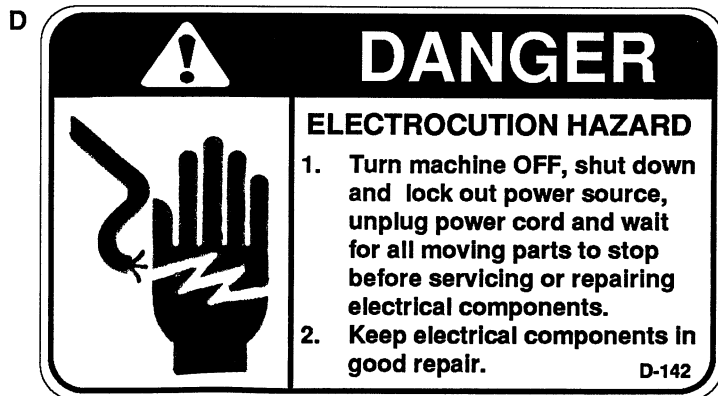
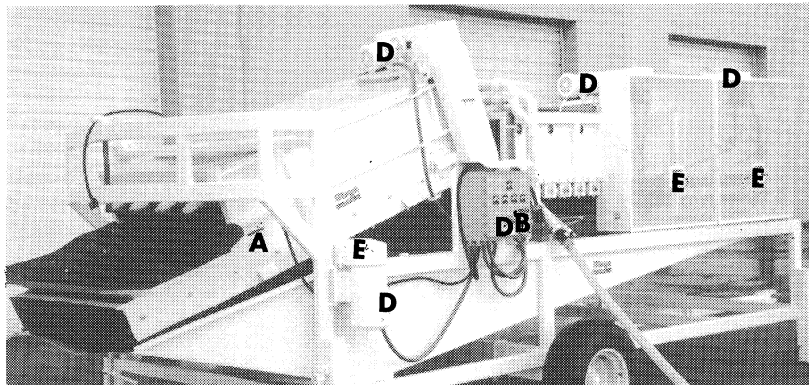
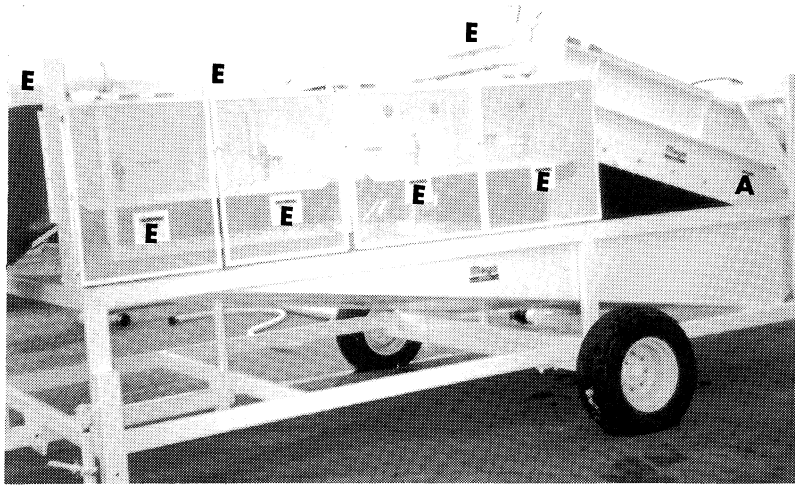


REMEMBER - If safety signs have been damaged, removed, become illegible or parts replaced without safety signs, new signs must be applied. New safety signs are available from your authorized dealer.

### 3 SAFETY SIGN LOCATIONS (cont'd)

The types of safety signs and locations on the equipment are shown in the illustration below. Good safety requires that you familiarize yourself with the various safety signs, the type of warning and the area, or particular function related to that area, that requires your SAFETY AWARENESS.

- Think SAFETY! Work SAFELY!



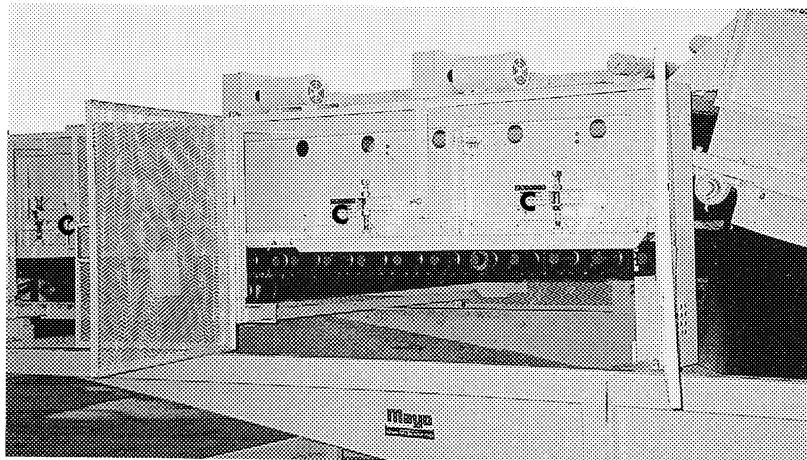
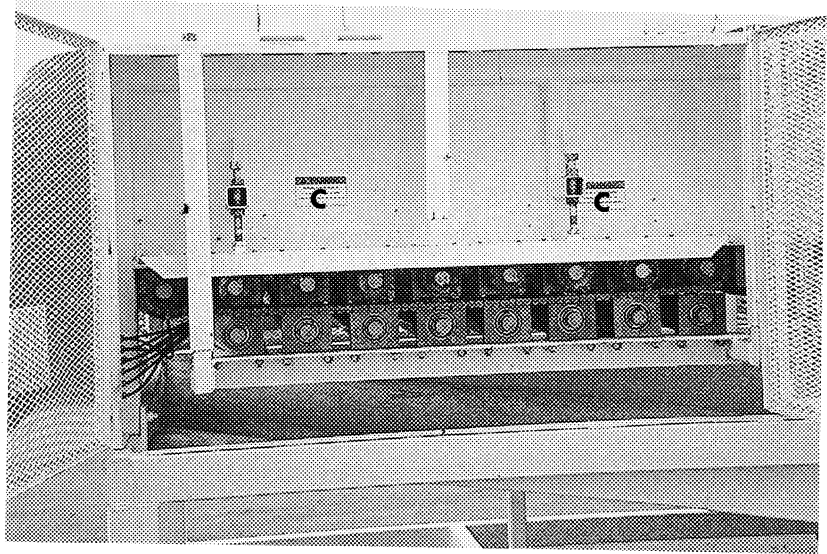
REMEMBER - If safety signs have been damaged, removed, become illegible or parts replaced without safety signs, new signs must be applied. New safety signs are available from your authorized dealer.



### 3 SAFETY SIGN LOCATIONS (cont'd)

The types of safety signs and locations on the equipment are shown in the illustration below. Good safety requires that you familiarize yourself with the various safety signs, the type of warning and the area, or particular function related to that area, that requires your SAFETY AWARENESS.

- Think SAFETY! Work SAFELY!



REMEMBER - If safety signs have been damaged, removed, become illegible or parts replaced without safety signs, new signs must be applied. New safety signs are available from your authorized dealer.

## 4 OPERATION



### OPERATING SAFETY

1. Read and understand the Operator's Manual and all safety signs before operating, maintaining, adjusting or repairing the Washer.
2. Turn machine OFF, shut down and lock out power supply (safety lockout devices are available through your Mayo dealer parts department), and wait for all moving parts to stop before servicing, adjusting, maintaining or repairing.
3. Install and properly secure all guards and shields before operating.
4. Keep hands, feet, hair and clothing away from all moving parts.
5. Clear the area of bystanders, especially small children, before starting.
6. Make sure all control switches are in the off position before connecting power supply.
7. Before supplying electrical power to the machine, be sure that you have adequate amperage at the proper phase and voltage to run it. If you do not know or are unsure, consult a licensed electrician.
8. Keep the working area clean and dry.
9. Review safety instructions annually.

#### 4.1 TO THE NEW OPERATOR OR OWNER

The Mayo Manufacturing Potato Washer is designed to wash potatoes to remove dirt, mud and residue prior to shipment for processing. Be familiar with the machine before starting.

**It is the responsibility of the owner or operator to read this manual and to train all other operators before they start working with the machine. Follow all safety instructions exactly. Safety is everyone's business. By following recommended procedures, a safe working environment is provided for the operator, bystanders and the area around the worksite. Untrained operators are not qualified to operate the machine.**

Many features incorporated into this machine are the result of suggestions made by customers like you. Read this manual carefully to learn how to operate the machine safely and how to set it to provide maximum efficiency. By following the operating instructions in conjunction with a good maintenance program, your Potato Washer will provide many years of trouble-free service.

## 4.2 MACHINE COMPONENTS

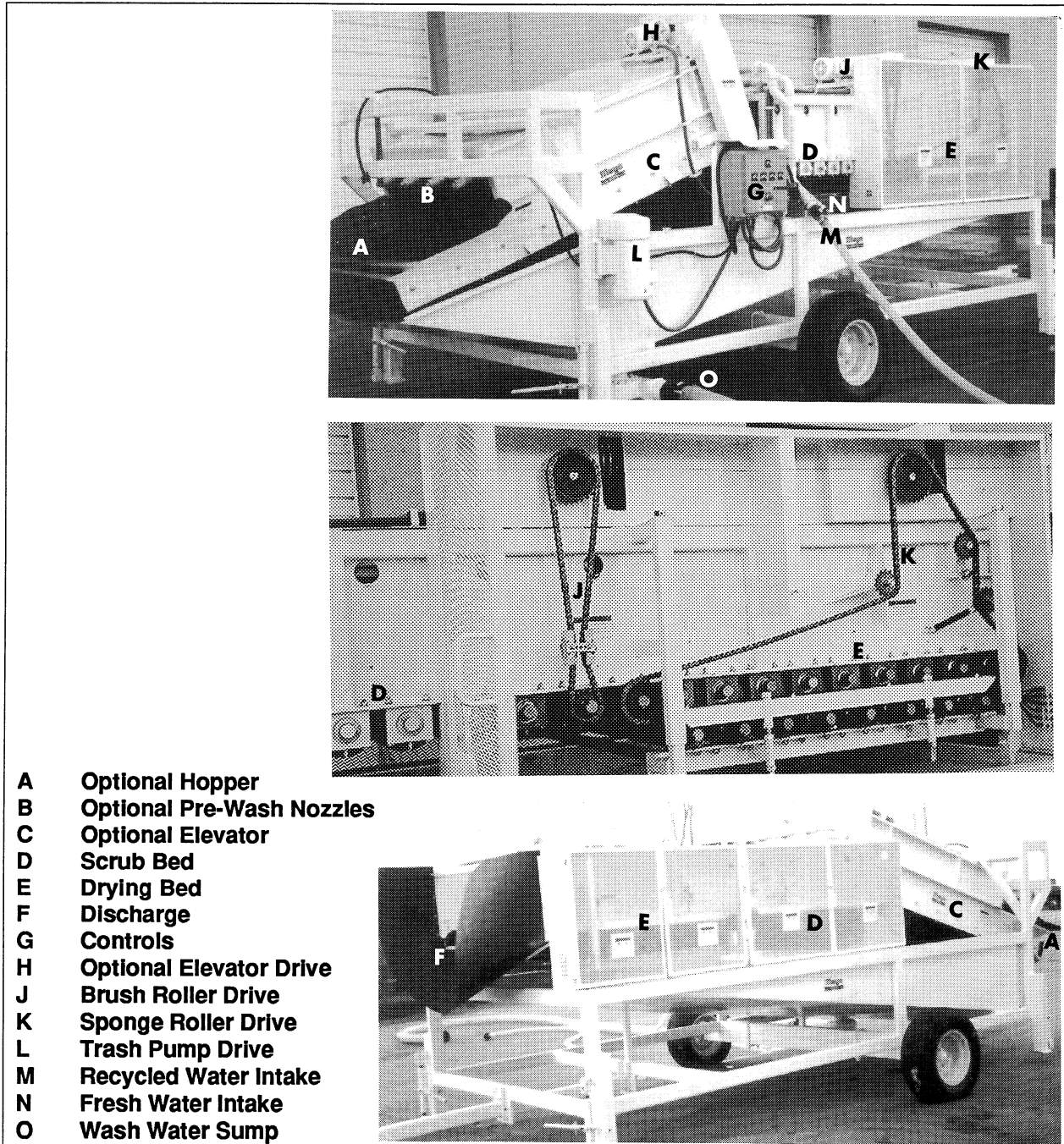
The Mayo Manufacturing Potato Washer consists of a hopper, elevator, wash bed and discharge for cleaning potatoes prior to shipment for processing. A washer is a component within a conveying line and is used to clean the potatoes.

An optional elevator moves the potatoes from the hopper up to the washing bed for scrubbing. Recycled wash water flows through a system of nozzles above the elevator and wash bed to loosen and remove dirt. The optional elevator is used as a soak or pre-wash area for the potatoes. A strong water spray from the nozzles coupled with brush rollers are used in the wash bed to remove dirt.

A set of nozzles across the wash bed discharge use fresh clean water to provide a final rinse as the potatoes leave the wash bed. Sponge rollers after the wash bed remove excess water from the potatoes. Compression rollers remove excess water from the sponge rollers. All the soak, wash, and rinse water drops into the collector where it is pumped out and discharged or recycled.

All electrical controls are mounted on a central control panel.

Ratchet jacks on each corner are used to level the machine and remove the weight from the tires. A removable hitch is used for transporting.



- A Optional Hopper
- B Optional Pre-Wash Nozzles
- C Optional Elevator
- D Scrub Bed
- E Drying Bed
- F Discharge
- G Controls
- H Optional Elevator Drive
- J Brush Roller Drive
- K Sponge Roller Drive
- L Trash Pump Drive
- M Recycled Water Intake
- N Fresh Water Intake
- O Wash Water Sump

Fig. 1 MACHINE COMPONENTS

### 4.3 GENERAL OPERATION THEORY

A Potato Washer is positioned in the line of conveying equipment that loads trucks to take the potatoes for processing. This unit can be located at a storage or transfer facility and used prior to the potatoes being loaded into the transport truck.

Fresh and recycled (cleaned or filtered) water must be provided to the machine by the customer at the required volume and pressure for optimum performance. Insufficient volume and pressure will compromise the washing performance.

Potatoes are fed into the optional elevator hopper of the Washer by one of several types of conveying machines which could include, but is not limited to a telescoping conveyor, a straight conveyor, a sizing conveyor, a chain conveyor, a transport truck, a holding hopper, etc.

From the elevator hopper the potatoes are carried by an optional chain conveyor up into the washing bed. When the potatoes are scrubbed, cleaned and finally rinsed with clean water at the end of the wash bed, they are discharged out the back of the machine. The customer must provide a means to remove the clean potatoes from the washer as they are discharged.

Minimize all drop heights to prevent bruising of the potatoes.

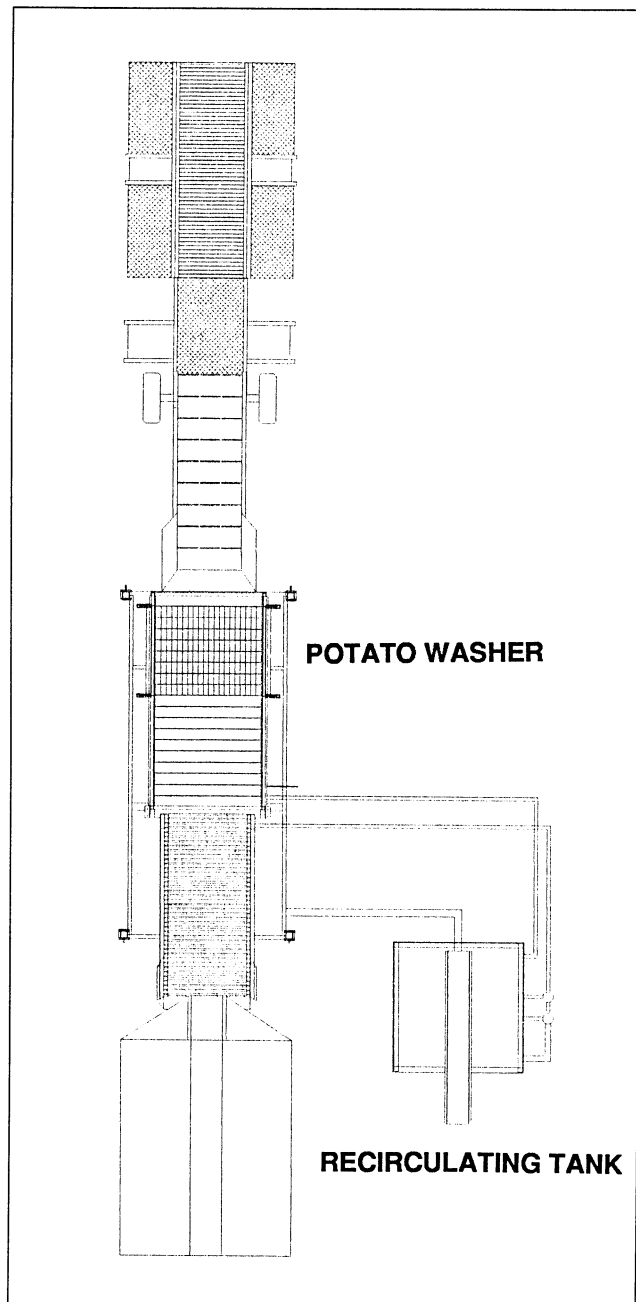


Fig. 2 POSITIONED (TYPICAL)

## 4.4 MACHINE BREAK-IN

Although there are no operational restrictions on the Washer when used for the first time, it is recommended that the following mechanical items be checked:

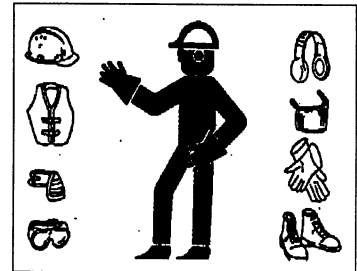
- A. Read Washer and auxiliary equipment manuals before starting.
- B. **After operating for 1/2 hour:**
  1. Retorque all wheel bolts.
  2. Retorque all other fasteners and hardware.
  3. Check the alignment of the optional conveyor chain. Realign as required.
  4. Check that all electrical connections are tight and cords are routed out of the way or protected.
  5. Check for leaks in water system.
  6. Check that no water lines are being pinched or crimped. Reroute as required.
  7. Check the alignment and tension of all drive belts and chains. Realign or tighten as required.
  8. Check all drive sprockets and pulleys to make sure none has moved. Re-align and tighten any that has moved.
  9. Check oil level in each speed reduction gear box for each drive. Top up as required.
  10. Lubricate all grease fittings.
- C. **After 2, 5 and 10 hours of operation:**
  1. Retorque all fasteners and hardware.
  2. Check the alignment of the optional conveyor chain. Realign as required.
  3. Check that all electrical connections are tight and cords are routed out of the way or protected.
  4. Check for leaks in water system. Retorque fittings that leak.
  5. Check that no water lines are being pinched or crimped. Reroute as required.
  6. Check the alignment and tension of all drive belts and chains. Realign or tighten as required.
  7. Check all drive sprockets and pulleys to make sure none has moved. Re-align and tighten any that has moved.
  8. Check oil level in each speed reduction gear box for each drive. Top up as required.
  9. Then go to the regular servicing and maintenance schedule as defined in the Maintenance Section.

## 4.5 PRE-OPERATION CHECKLIST

Safe and efficient operation of your new Washer requires that each operator reads and follows all safety precautions and operating procedures contained in this section. Performing the following pre-operation checklist is important for personal safety as well as for continued mechanical soundness and longevity of your new Mayo Washer. The checklist should be performed before operating the Washer and prior to each operation thereafter.

1. Lubricate the machine according to the schedule prescribed in the "Maintenance Section".
2. Insure that proper protective gear is in good repair and available for use by each operator. Make certain that each operator uses the protective gear. Protective gear includes but, is not limited to:

- Leather gloves
- Safety glasses or face shield
- Full length protective clothing
- Steel toed boots with slip resistant soles.



3. Check for water leaks. Tighten fittings or reroute hoses as required to maintain a leak-free system.
4. Insure that all safety guards and shields are in good repair and securely in place.
5. Check that the optional conveyor chain is centered on the head and tail rollers. Adjust if necessary as outlined in the "Maintenance Section".
6. Check that all drive belts and chains are properly tensioned and aligned. Adjust if required.
7. Check the condition of the brush and foam rollers. Replace any that are damaged, clogged or broken.
8. Check for and remove all entangled material.
9. Make sure that all electrical switches are in the OFF position before supplying power.
10. Check that all electrical connections are tight and cords are routed out of the way or protected.
11. Be sure the working area is clean and dry to prevent tripping or slipping.

## 4.6 CONTROLS

It is recommended that all operators review this section of the manual to familiarize themselves with the location and function of all machine controls before starting. Some machines may vary slightly due to custom features but they are similar and all controls are labelled.

### 1. Master OFF/ON

This 2 position rotary switch controls the power to the control panel. Turn counter-clockwise to turn OFF and clockwise to turn ON. The switch must be turned ON before using any other switch or function.

### 2. Trash Pump STOP/START:

This 2 position rotary switch controls the power to trash pump electric motor. Turn counter-clockwise to turn OFF and clockwise to turn ON. This pump removes the wash water from the bottom of the machine.

### 3. Elevator STOP/START:

This 2 position rotary switch controls the power to the electric motor that drives the elevator. Turn counter-clockwise to turn OFF and clockwise to turn ON.

### 4. Brush Rollers STOP START:

This 2 position rotary switch controls the power to the electric motor driving the brush rollers. Turn counter-clockwise to turn OFF and clockwise to turn ON.

### 5. Sponge Rollers STOP/START:

This 2 position rotary switch controls the power to the electric motor driving the sponge rollers. Turn counter-clockwise to turn OFF and clockwise to turn ON.

### 6. Emergency STOP Control:

This red push/pull button is the emergency STOP control for the machine and stops all functions. Push the control in for emergency STOP. Place all the individual controls in their OFF position. Before the machine can be restarted, the Emergency STOP button must be pulled out. If the individual controls are not all placed in their OFF position when the STOP button is pulled out, all the motors will try to start at the same time. **DO NOT use the emergency STOP switch as a master start switch.**

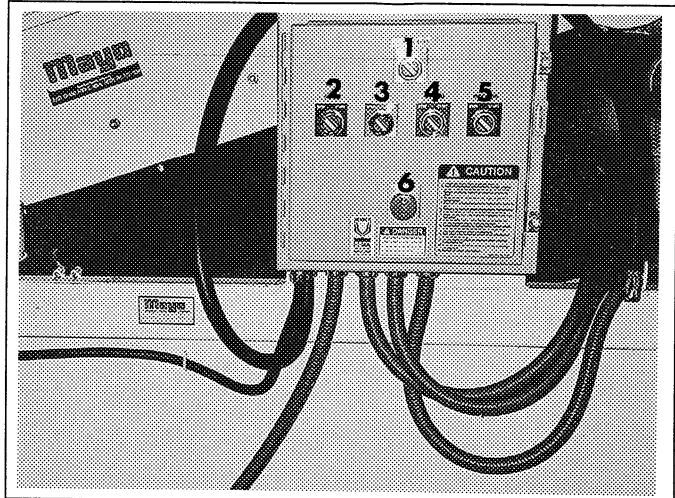


Fig. 3 ELECTRIC PANEL CONTROLS

## 4.7 MACHINE PREPARATION

The machine must be properly prepared prior to using. Before starting machine, be sure that the following items are appropriate for your machine and operating requirements:

1. **Power:**  
**Have a licensed electrician provide power at the required voltage, phase and amperage for your machine. An improper source of power will cause damage to electrical components and could create an electrical hazard to the operator, worker or bystanders.**

Be sure to use an extension cord of the correct specifications for the power being carried. Route the cord so that it does not interfere with the working area. Provide appropriate protection when people or equipment must go over the cord. Inspect the cord occasionally to be sure it is not damaged. Replace immediately if it is damaged.

2. **Hitch:**  
Each machine is equipped with a removable hitch that is used to move and transport the washer. Remove the anchor bolt and slide the hitch out of the frame to prevent tripping.

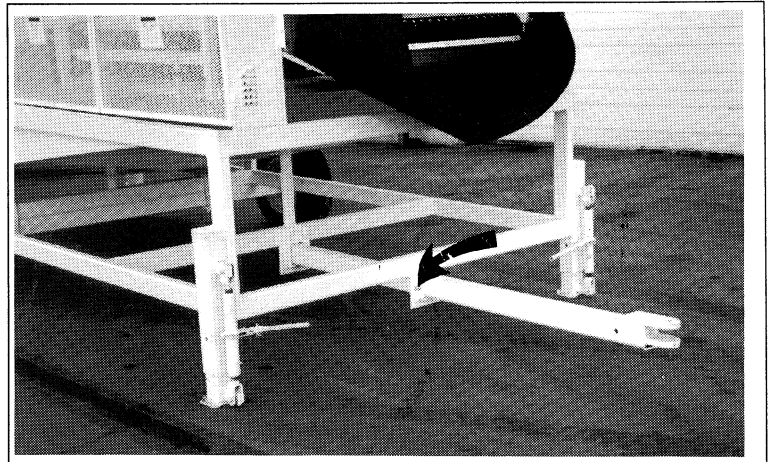


Fig. 4 HITCH ANCHOR BOLT

3. **Frame Jacks:**  
The machine is equipped with jacks on each frame corner. Lower jacks to the ground to carry the weight when the machine is in its operating position. Raise jacks to their up position for moving and transporting.

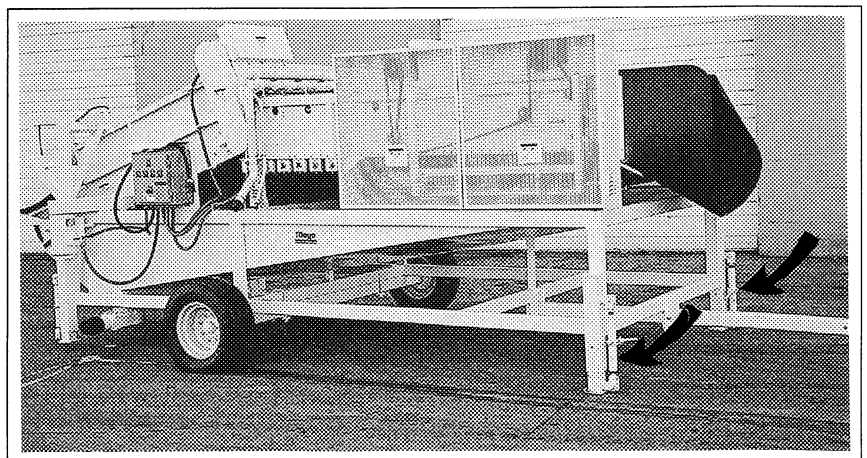
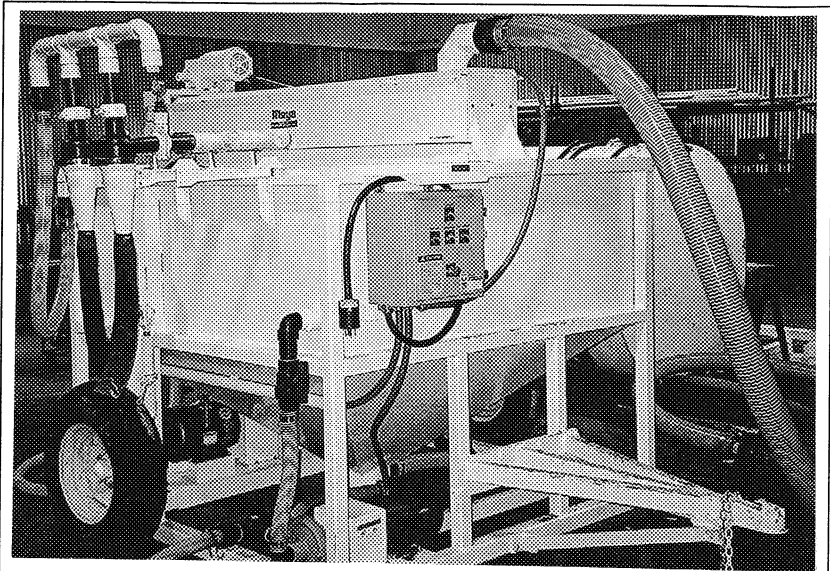


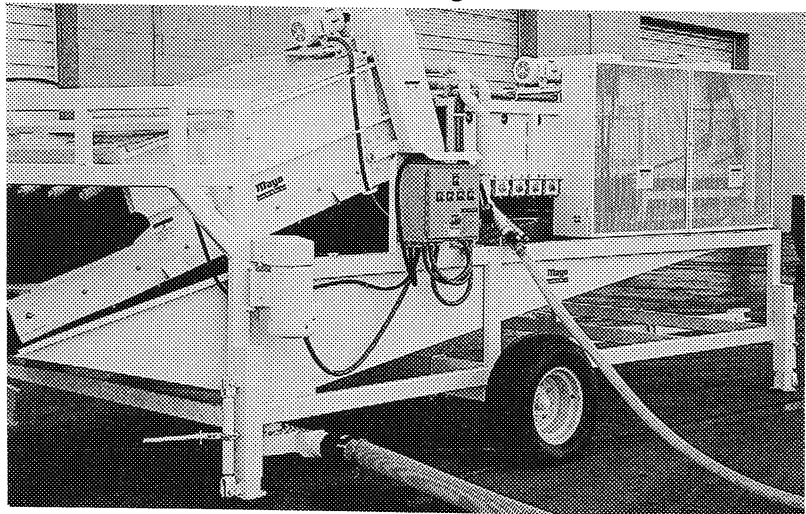
Fig. 5 FRAME JACKS

**4. Water Supply:**

Provide a 200 gpm 35-40 psi source of water to the machine. Normally the water from the bottom sump is filtered or cleaned and then recycled back through the wash nozzle system. The Mayo 12000 Series Recirculating Tank works well for recycling and cleaning an adequate supply of water. In addition, a 3 gpm 35-40 psi source of fresh water is required for the final rinse.



**Recirculating Tank**

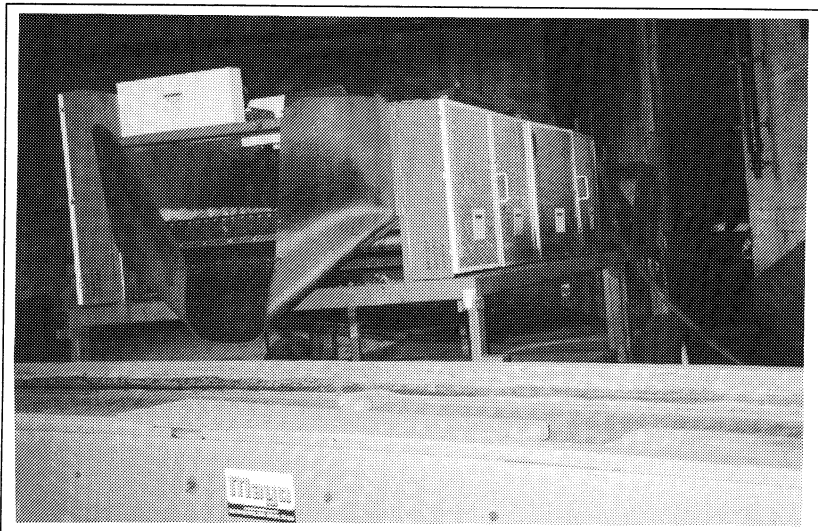


**Connection**

**Fig. 6 WATER SUPPLY**

**5. Auxiliary Equipment:**

Each customer must provide a means of bringing a flow of potatoes to the hopper end and removing them from the discharge end. Normally this is done by another piece of equipment such as a grader or another conveyor. Always connect the adjacent equipment securely to the washer to prevent movement.



**Fig. 7 AUXILIARY EQUIPMENT**



## 4.8 OPERATING



# OPERATING SAFETY

1. Read and understand the Operator's Manual and all safety signs before operating, maintaining, adjusting or repairing the Washer.
2. Turn machine OFF, shut down and lock out power supply (safety lockout devices are available through your Mayo dealer parts department), and wait for all moving parts to stop before servicing, adjusting, maintaining or repairing.
3. Install and properly secure all guards and shields before operating.
4. Keep hands, feet, hair and clothing away from all moving parts.
5. Clear the area of bystanders, especially small children, before starting.
6. Make sure all control switches are in the off position before connecting power supply.
7. Before supplying electrical power to the machine, be sure that you have adequate amperage at the proper phase and voltage to run it. If you do not know or are unsure, consult a licensed electrician.
8. Keep the working area clean and dry.
9. Review safety instructions annually.

Follow this procedure when using the Washer:

1. Review Section 4.7 Machine Preparation and follow all the instructions.
2. Review and follow the pre-operation checklist (See Section 4.5).
3. Review the location and function of all controls (See Section 4.6).
4. **Water Supply:**
  - a. Provide a supply of recycled water to the machine using the over-center cam lock coupler provided with the machine to the 2 inch input line. Be sure the cam locks go over center to provide a good seal.
  - b. Provide a supply of fresh water to the 3/4" final rinse line. Be sure the cam locks go over center to provide a good seal.
  - c. Attach the 4 inch sump outlet to the recycling machine line. Be sure the cam lock coupler goes over-center to provide a good seal.

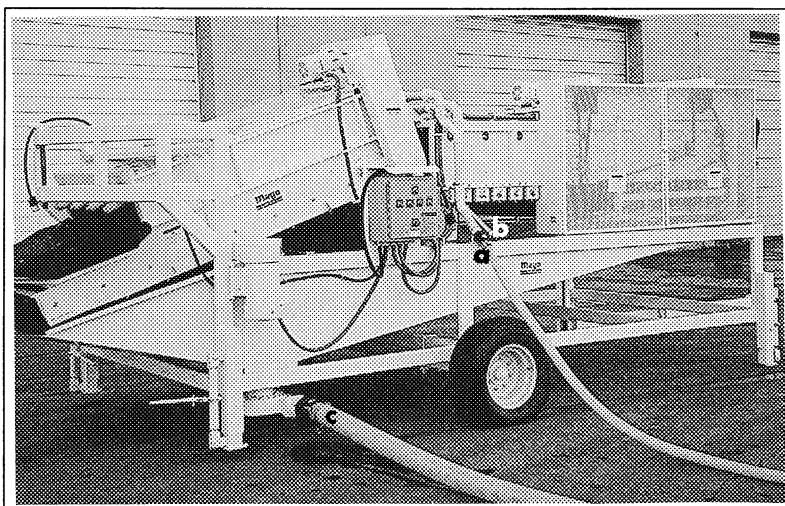


Fig. 8 WATER SUPPLY

5. **Starting Washer:**
  - a. Clear the area of bystanders. Know where everyone is before starting.
  - b. Place all controls in the OFF position.
  - c. Turn the power to the machine ON at the master panel.
  - d. Turn the master power switch ON (Refer to Section 4.7 Controls).

**NOTE**

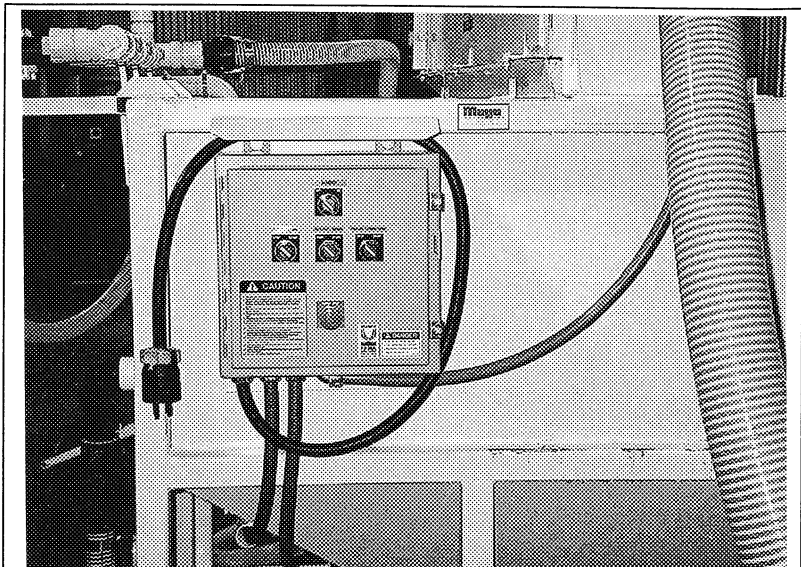
Be sure the red Emergency Stop switch is pulled out.

- e. Turn the water supply ON.
- f. Turn the trash pump ON.
- g. Turn the sponge rollers ON.
- h. Turn the brush rollers ON.
- i. Turn the optional elevator ON.
- j. Turn the equipment ON that moves potatoes to and from the Washer.

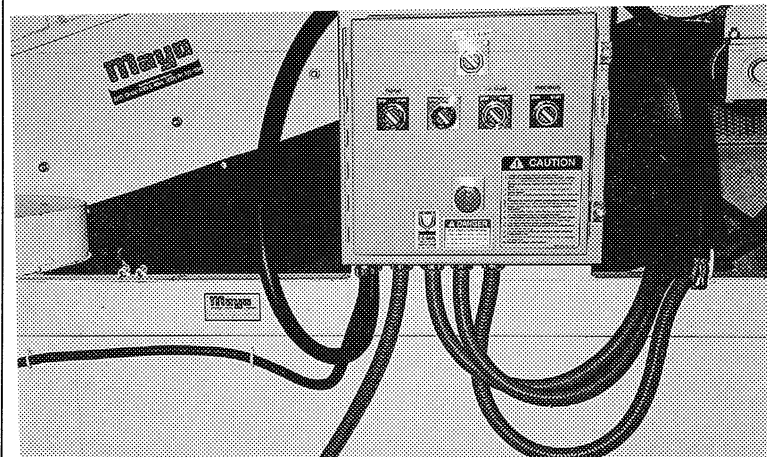
6. **Stopping machine:**
  - a. Turn OFF the equipment that brings potatoes to the Washer.
  - b. Wait until the potatoes have moved out the end of the Washer.
  - c. Turn the optional elevator OFF.
  - d. Turn the brush rollers OFF.
  - e. Turn the sponge rollers OFF.
  - f. Turn the trash pump OFF.
  - g. Turn the Master OFF/ON switch OFF.
  - h. Turn the water supply OFF.

An alternative is to depress the red Emergency STOP button on the control panel but then the operator must go through steps a through h to turn all the controls OFF before restarting.

7. **Emergency STOP:**  
 Depress the large red STOP button on the control panel. This will stop the elevator, rollers and trash pump. Be sure to turn all the individual control switches to their OFF position and pull the Emergency Stop button out before restarting the machine.



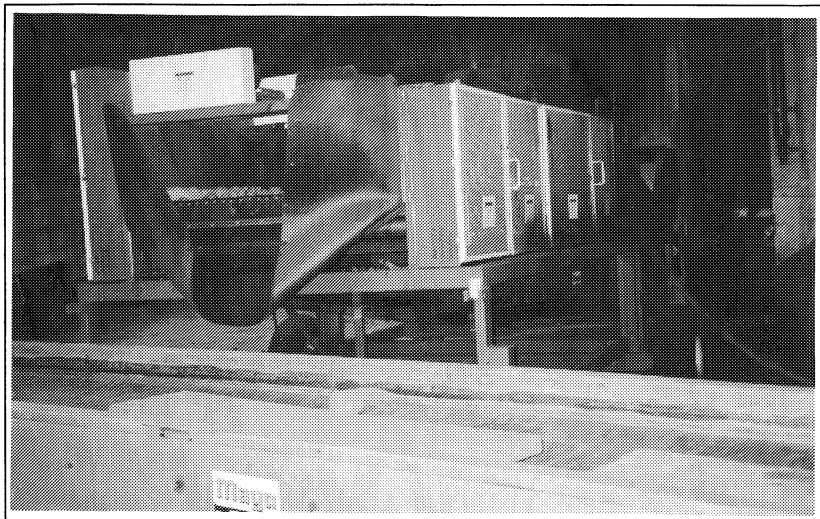
**Recirculating Tank**



**Washer**

**Fig. 9 CONTROL PANELS**

8. **Auxiliary Equipment:**  
Provide a means for bringing a flow of potatoes to the hopper end and a means for removing them from the discharge. Since the Washer is positioned on jacks for operation, it will not move. Do not allow the auxiliary equipment to move. Normally connecting them will prevent movement.



**Fig. 10 AUXILIARY EQUIPMENT**

9. **Moving:**  
All machines are equipped with a removable hitch on the hopper end that is secured with an anchor bolt. The hitch can be removed if desired if it interferes with the working area.

Raise the jack stands and disconnect the water and power supplies prior to moving the machine. Always install lights and an SMV emblem before transporting on a public road.

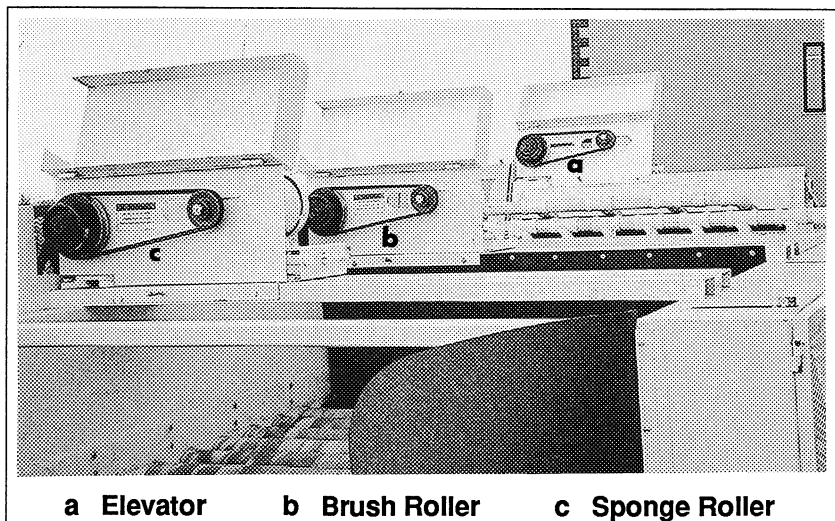


**Fig. 11 MOVING**

10. **Machine Speed:**  
The input drives for the elevator and each type of roller are equipped with a variable pulley belt drive for setting the machine speeds. Use cleanliness of the potatoes out of the discharge as a guide when setting the speed of the machine.

Increase the speed of the systems if the potatoes are clean and decrease if the potatoes are not clean. Move the drive pulley closer to the driven pulley to increase speed and away to decrease.

Normally, the optional elevator is set to run slowly to allow the potatoes to soak before they get to the brush rollers. Use this as a pre-wash or soak cycle.



**Fig. 12 MACHINE SPEED - BELT DRIVES**

**11. Nozzles:**

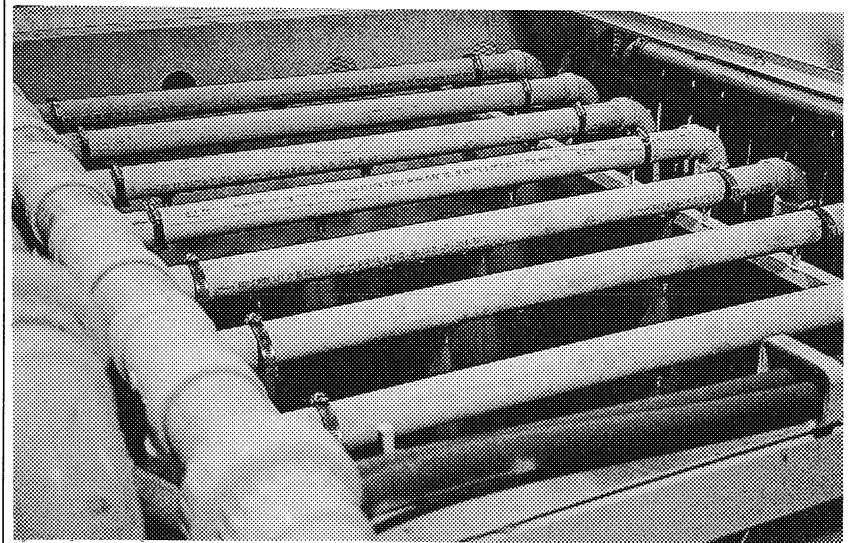
Nozzles are used in the wash circuit to distribute the water over the potatoes. A wide angle nozzle is used over the optional elevator to be sure that there is sufficient water for a good pre-soak to wet and loosen dirt.

Nozzles with a narrow spray angle for higher force are used over the wash bed to assist the brushes in removing dirt from the potatoes.

Check the spray pattern from the nozzles every 8-10 hours to be sure that none of the nozzles are plugged or have a poor spray pattern. When this occurs, clean or replace them.



**Elevator**



**Wash Bed**

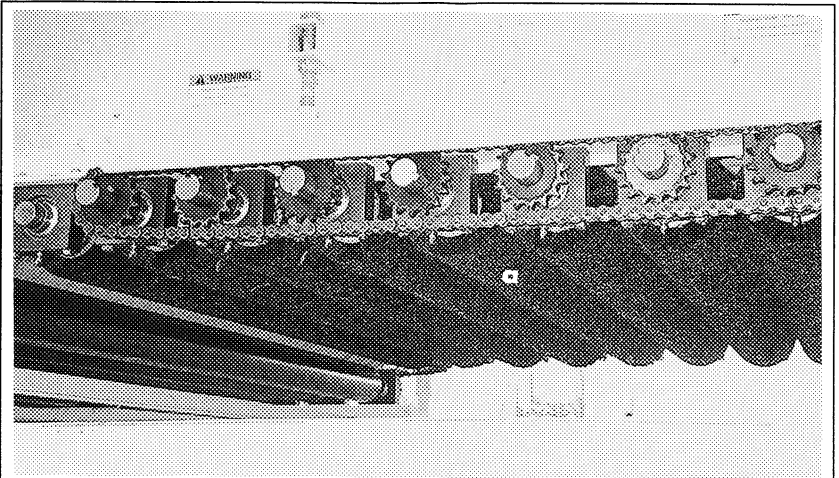
**Fig. 13 NOZZLES**

## 12. Rollers:

Three types of rollers are used on the machine and perform special functions:

### a. Brush Rollers:

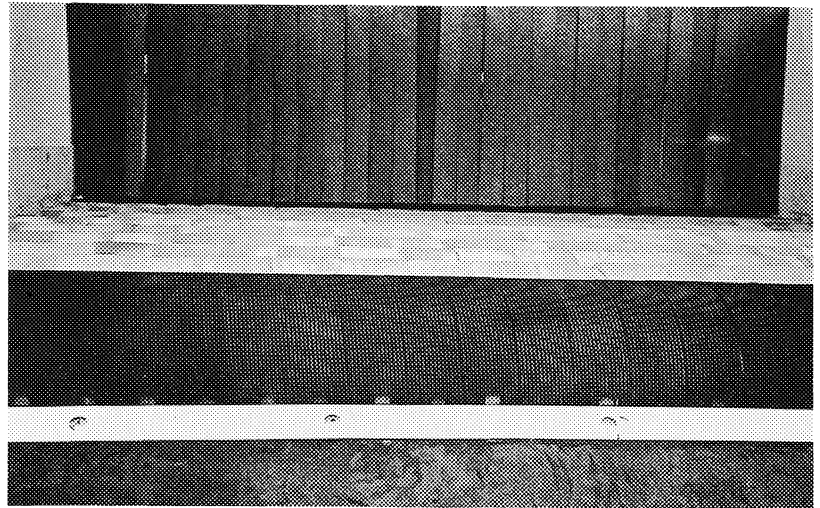
These rollers are positioned under the washing bed to roll the potatoes and brush away the dirt. They function best when the flow of potatoes is one level deep. Allow the water to run for at least 1 minute after all the potatoes have passed through the washing bed to clean the brushes.



Brush

### b. Sponge Rollers:

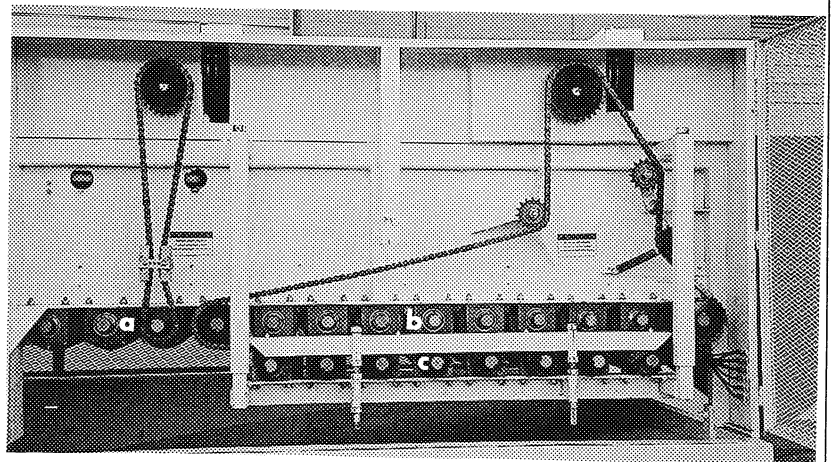
These rollers are used under the drying bed to remove any excess water from the potatoes before they are discharged from the machine. Wash the rollers with a garden hose using fresh water to clean if required. Replace if damaged.



Sponge

### c. Squeeze Rollers:

These rollers are used under the sponge rollers to squeeze the sponge and remove all excess moisture from the roller. Compressing the sponge on the roller 1/4 inch is sufficient to remove the excess moisture. Compressing more than 1/4 inch will only damage the sponge without removing any more moisture.

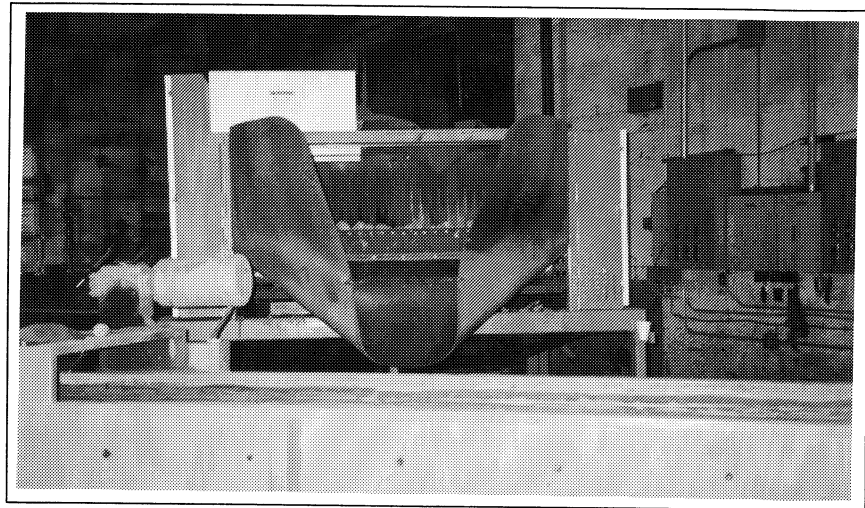


Squeeze

Fig. 14 ROLLERS

**13. Bruising:**

Potatoes are sensitive to bruising during the gathering, transporting, storage and handling phases of their growing. Bruising is kept to a minimum by maintaining a full flow of potatoes through each machine and minimizing all drop heights. Bruising, during the washing phase, can be minimized by keeping the drop height between each machine as small as possible.



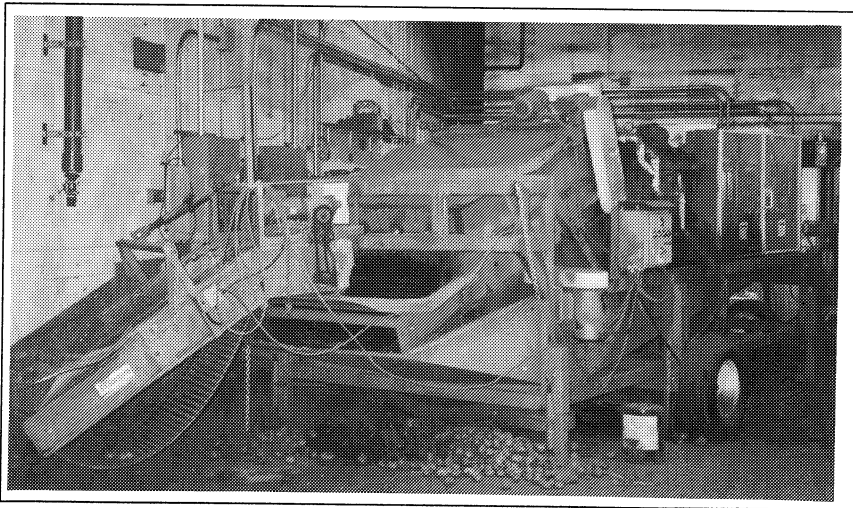
**Fig. 15 DROP HEIGHT**

**14. Water Quality:**

It is recommended that the customer provide a means to clean the wash water as it is pumped out of the sump. Although filters or cleaning systems remove the dirt and trash, they do not remove all the fines. After recycling the water for a period of time, the fines will accumulate and the water will get dirty. Change the water when this happens.

**15. Operating Hints:**

- a. Be sure that all workers and operators are supplied with and use the required safety gear.
- b. Keep the working area clean and as dry as possible to prevent slipping and tripping.
- c. Train all operators before starting. An untrained operator is not qualified to operate this machine and can expose himself and others to needless hazards.
- d. Secure all pieces of equipment together to prevent unexpected movement and separation.
- e. Keep the elevator as full as possible to minimize bruising during the washing process.



**Fig. 16 OPERATING SYSTEM**

## 4.9 TRANSPORT



# TRANSPORT SAFETY

1. Make certain that you are in compliance with local, state/provincial and federal regulations regarding transporting agricultural equipment on public roadways.
2. Make certain that all wheels and tires are in good repair and that tires are inflated to proper pressure. Do not underinflate or overinflate.
3. Make certain that all wheel bolts/lug nuts are tightened to proper torque specifications (refer to specification chart in Section 7.2).
4. Make certain that all mechanical locks and integral anchor chains are safely and positively connected before loading or transporting.
5. Raise and secure all jack stands.
6. Wrap up and bind to the frame all loose water line and electrical ends.
7. Be sure that any necessary SMV (slow moving vehicle) signs, reflectors and lights required by law are in proper place and are clearly visible to oncoming and overtaking traffic.
8. Be sure that the Washer is positively hitched to the towing vehicle. Use a proper safety chain to assure a safe hitch hook-up when transporting.
9. Adhere to local regulations regarding maximum weight, width and length.
10. Do not exceed 20 MPH (32 Km/H). Reduce speed on rough roads and surfaces.
11. Do not allow anyone to ride on the Washer or towing vehicle during transport.
12. Always use hazard flashers on the towing vehicle when transporting.

Mayo Washers are designed to be easily and conveniently moved from location to location. The term moving is used to describe the action of moving the machine within a storage facility. Transporting is used to describe when the machine is being towed by a tractor or other power unit on a public highway. When transporting, follow this procedure:

1. Disconnect and remove all auxiliary equipment from the Washer and position so the tractor can back up to the front of the machine.
2. Disconnect the water supply and sump hoses. Drain the sump and plumbing.



Fig. 17 WATER HOSES

## 4.9 TRANSPORT (cont'd)

3. Install and secure the tow hitch.
4. Attach the tow hitch to the tractor. Be sure to use a mechanical retainer through the drawbar pin.
5. Attach a safety chain between the hitch and the drawbar cage to prevent unexpected separation.
6. Install an SMV on the rear frame.



**Fig. 18 TOW HITCH**

7. Use pilot vehicles or install extra lights on the machine when transporting.
8. Clean all the reflectors.
9. Place all controls in their OFF or neutral position.
10. Turn the power OFF at the master panel and lock out.
11. Unplug and remove the power cord.
12. Be sure all bystanders are clear of the machine.
13. Keep to the right and yield the right-of-way to allow faster traffic to pass. Drive on the road shoulder, if permitted by law.
14. Make sure the SMV (Slow Moving Vehicle) emblem and all the lights and reflectors that are required by the local highway and transport authorities are in place, are clean and can be seen clearly by all overtaking and oncoming traffic.
15. It is not recommended that the machine be transported faster than 20 mph (32 km/hr). Table 1 gives the acceptable transport speed as the ratio of tractor weight to Washer weight.
16. Do not allow riders on the machine or tractor.
17. Always use hazard flashers on the tractor when transporting unless prohibited by law.

**Table 1 Travel Speed vs Weight Ratio**

<u>Road Speed</u>	<u>Weight of fully equipped or loaded implement(s) relative to weight of towing machine</u>
Up to 25 km/h (15 mph)	1 to 1, or less
Up to 16 km/h (10 mph)	2 to 1, or less
Do not tow	More than 2 to 1



## 4.10 STORAGE



### STORAGE SAFETY

1. Store the Washer on a firm level surface.
2. If required, make sure the unit is firmly blocked up.
3. Make certain that all mechanical locks are safely and positively connected before storing.
4. Store away from areas of human activity.
5. Do not allow children to play on or around the stored Washer.
6. Lock out power by turning off master control panel or junction box and padlocking the door shut to prevent electrocution or unauthorized start up of the Washer.

#### 4.10.1 PLACING IN STORAGE

At the end of the season, the machine should be thoroughly inspected and prepared for storage. Repair or replace any worn or damaged components to prevent any unnecessary down time at the beginning of the next season. Follow this procedure:

1. Use fresh water to flush the water system to remove all contaminants. Check the spray pattern of each nozzle. Clean or replace any nozzle with an unusual pattern.
2. Check all rotating parts for entangled material. Remove.
3. Inspect the optional conveyor chain. Realign if the chain is not tracking in the sprockets. Properly tension the chain if required.
4. Turn the power OFF at the master electrical panel and lock out.
5. Unplug and remove power cord from machine.
6. Thoroughly wash the machine using a pressure washer to remove all dirt, mud, debris or residue. Be sure the brush and sponge rollers are cleaned.

7. Lubricate all grease fittings. Make sure all grease cavities have been filled with grease to remove any water residue from the washing.
8. Inspect all the water hoses, lines, fittings and nozzles. Tighten any loose fittings. Replace any hose that is badly cut, nicked, abraded or separating from a fitting. Replace any damaged components.
9. Inspect all the electrical cords, lines, junction boxes and motors. Tighten any loose connections. Replace any cord that is badly cut, nicked or abraded. Replace any damaged components.
10. Inspect each conveyor drive system. Check the condition of the roller chains and belts. Replace any if badly worn. Check the alignment of the sprockets and pulleys. Align if required. Properly tension each drive chain.
11. Apply a light coat of oil to each roller chain to prevent rusting.
12. Touch up all paint nicks and scratches to prevent rusting.
13. Select a storage area that is dry, level and free of debris.
14. Cover with a weather-proof tarpaulin and tie down if stored outside.

#### 4.10.2 REMOVING FROM STORAGE

When preparing to use the machine at the start of the season, follow this procedure:

1. Remove the tarpaulin if covered.
2. Transport or move to the working area.
3. Check
  - a. Water and electrical systems and components.
  - b. Optional conveyor chains and all drive systems.
  - c. All hardware. Tighten as required.
  - d. Air pressure in tires. Add as required.
4. Replace any defective components.
5. Go through the pre-operation checklist (Section 4.5) before starting.

# 5 SERVICE AND MAINTENANCE



## MAINTENANCE SAFETY

1. Read and understand all the information contained in the Operator's Manual regarding operating, servicing, adjusting, maintaining and repairing.
2. Turn machine OFF, shut down and lock out power supply (safety lockout devices are available through your Mayo dealer parts department), and wait for all moving parts to stop before servicing, adjusting, maintaining or repairing.
3. Follow good shop practices:
  - Keep service area clean and dry.
  - Be sure electrical outlets and tools are properly grounded.
  - Use adequate light for the job at hand.
4. Make sure all guards and doors are in place and properly secured when operating the Washer.
5. Do not work on Washer electrical system unless the power cord is unplugged and the power supply is locked out.

## 5.1 SERVICE

### 5.1.1 FLUIDS AND LUBRICANTS

1. Grease  
Use an SAE multi-purpose high temperature grease with extreme pressure (EP) performance meeting or exceeding the NLGI #2 rating for all requirements.
2. Speed Reducer Gear Box Lubricant  
Use a Browning Worm Gear high-temperature GL32HT lubricant (AGMA Comp. #8) or equivalent.

### 3. Roller Chain Lubricating Oil

CHAIN TYPE *	AMBIENT TEMPERATURE RANGE		
	14°F - 32°F	32°F - 104°F	104°F - 122°F
RS-50-less	SAE 10	SAE 20	SAE 30
RS-60/RS-80	SAE 20	SAE 30	SAE 40
RS100	SAE 20	SAE 30	SAE 40
RS120/MORE	SAE 30	SAE 40	SAE 40

\* Stamped on chain link side plate

### 4. Storing Lubricants

Your machine can operate at top efficiency only if clean lubricants are used. Use clean containers to handle all lubricants. Store them in an area protected from dust, moisture and other contaminants.

## 5.1.2 GREASING

Refer to Section 5.1.1 for recommended grease. Use the Maintenance Checklist provided to keep a record of all scheduled maintenance.

1. Use only a hand-held grease gun for all greasing. Air powered greasing systems can damage the seals on bearings and lead to early bearing failure.
2. Wipe grease fitting with a clean cloth before greasing to avoid injecting dirt and grit.
3. Replace and repair broken fittings immediately.
4. If a fitting will not take grease, remove and clean thoroughly. Also clean lubricant passageway. Replace fitting if necessary.
5. **Conveyor Bearings:**  
Only sealed bearings are used on the conveyor and roller bearings. Sealed bearings should never be greased more often than weekly or every 50 hours. Do not over-grease. Do not give bearing more than 1 shot of grease each time it is greased. (Once the bearing seal is broken, the bearing must be greased each day or the bearing will fail.)

### 5.1.3 SERVICING INTERVALS

#### 8 Hours or Daily

1. Oil the elevator drive system roller chain (1 location).

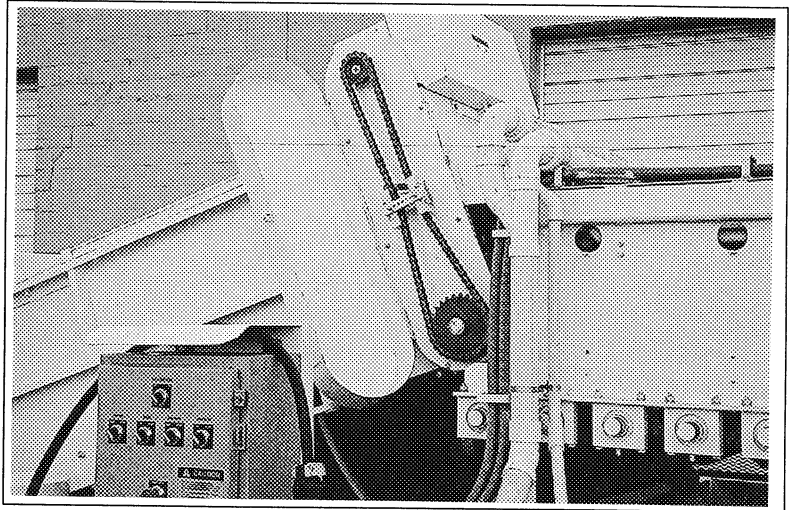
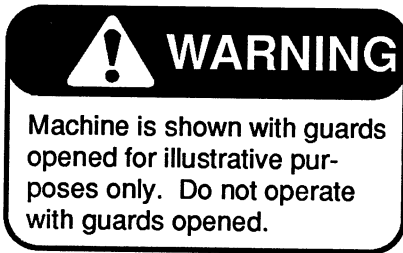
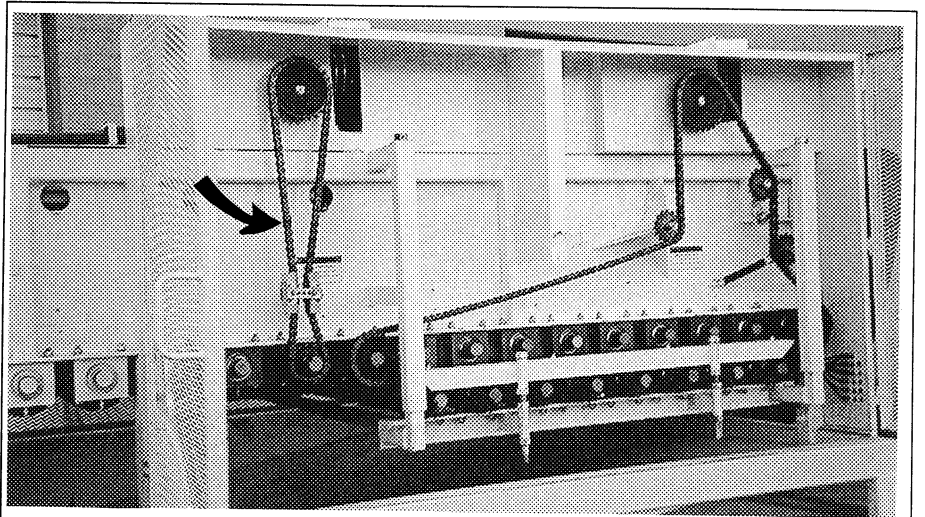


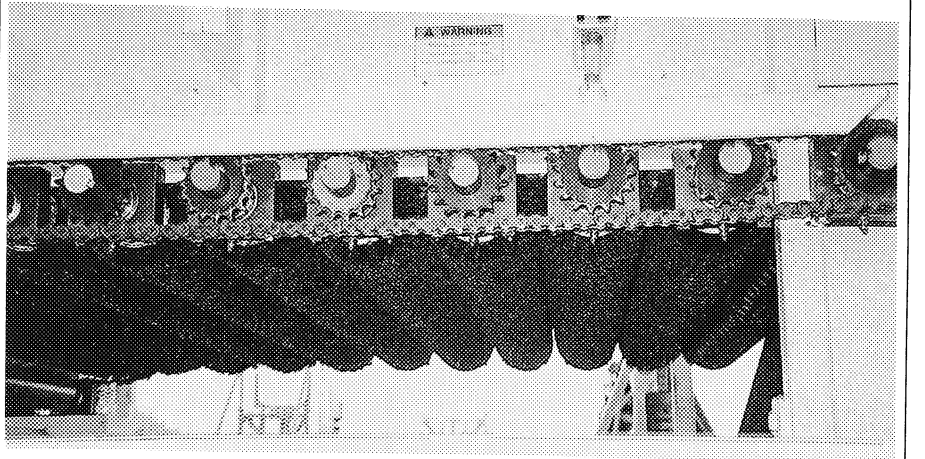
Fig. 19 ELEVATOR DRIVE



2. Oil the brush roller drive system primary and secondary roller chain (2 locations).



Primary



Secondary

Fig. 20 BRUSH ROLLER DRIVE

### 5.1.3 SERVICING INTERVALS (cont'd)

#### 8 Hours or Daily (cont'd)

3. Oil the sponge roller drive system primary and secondary roller chain (2 locations).
4. Check the optional elevator tension and alignment. Tension or align as required.
5. Inspect water system and all components.
6. Inspect electrical system and all components.

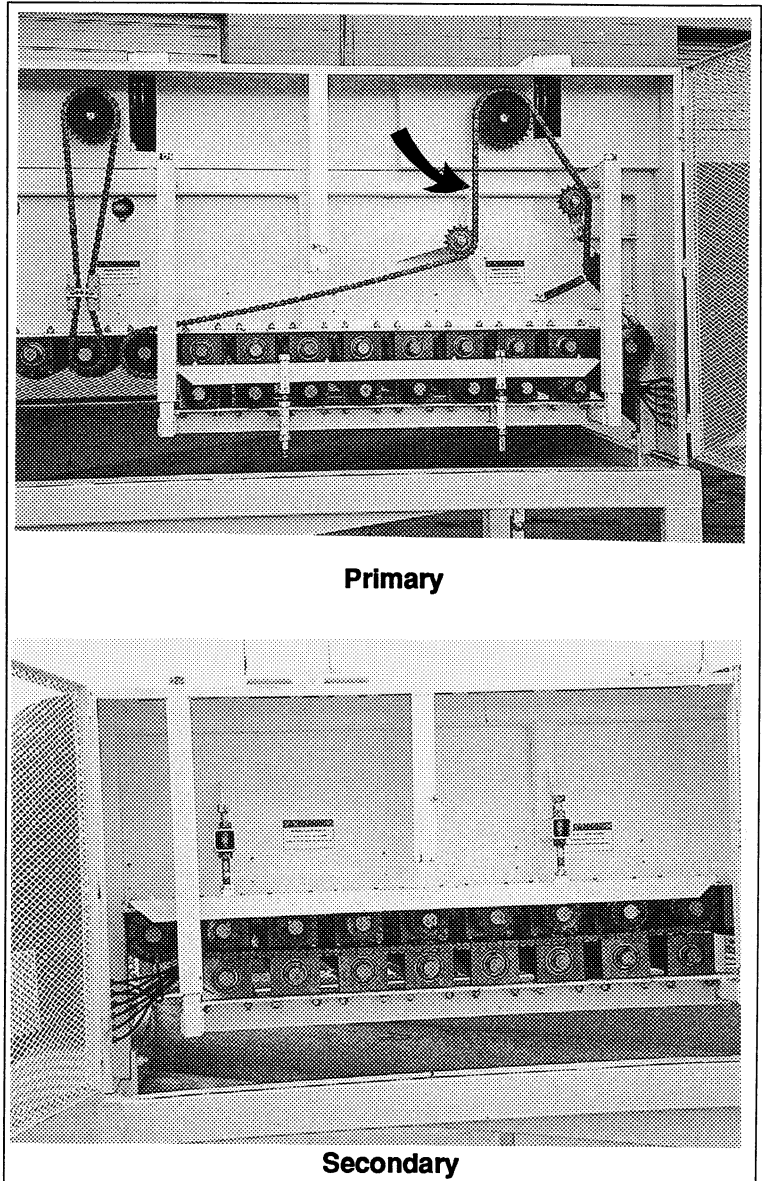
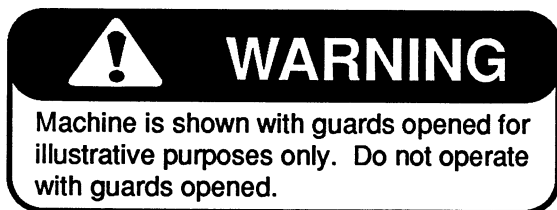


Fig. 21 SPONGE ROLLER DRIVE



## Weekly or 50 Hours

1. Grease elevator drive shaft bearings with 1 shot of grease (2 locations).

### IMPORTANT

Only sealed bearings are used on the conveyor bearings. Sealed bearings should never be greased more often than weekly or every 50 hours. Do not over-grease. Do not give bearing more than 1 shot of grease each time it is greased. Once the bearing seal is broken, the bearing must be greased each day or the bearing will fail.

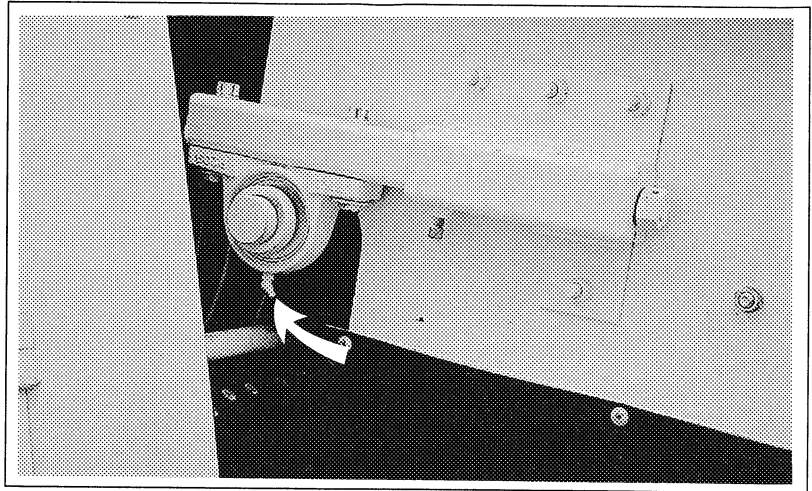


Fig. 22 ELEVATOR DRIVE

2. Grease the brush roller shafts with one shot of grease (2 locations each shaft).

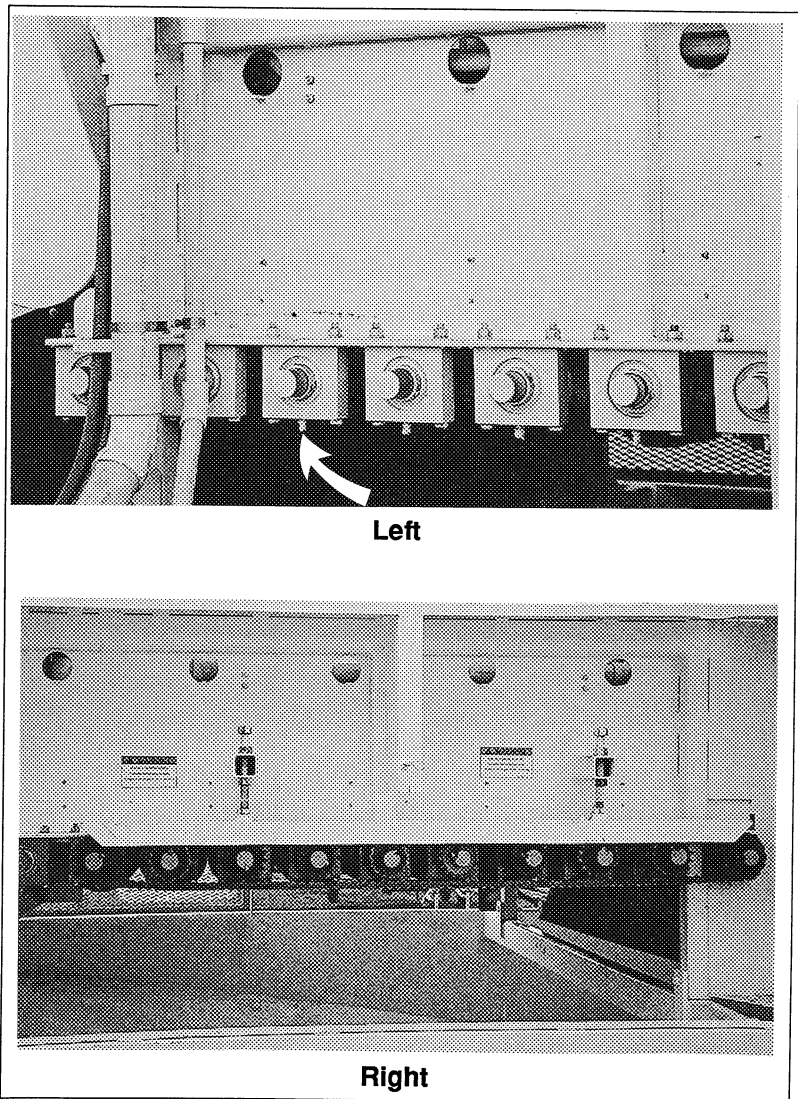
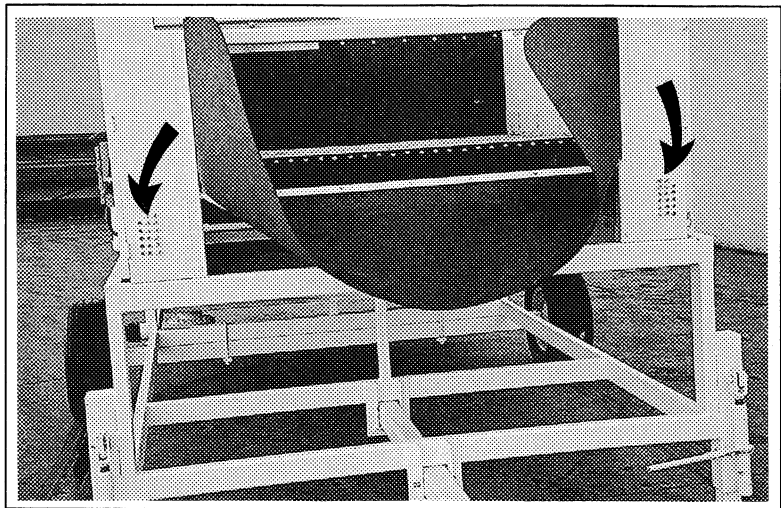


Fig. 23 BRUSH ROLLER SHAFTS

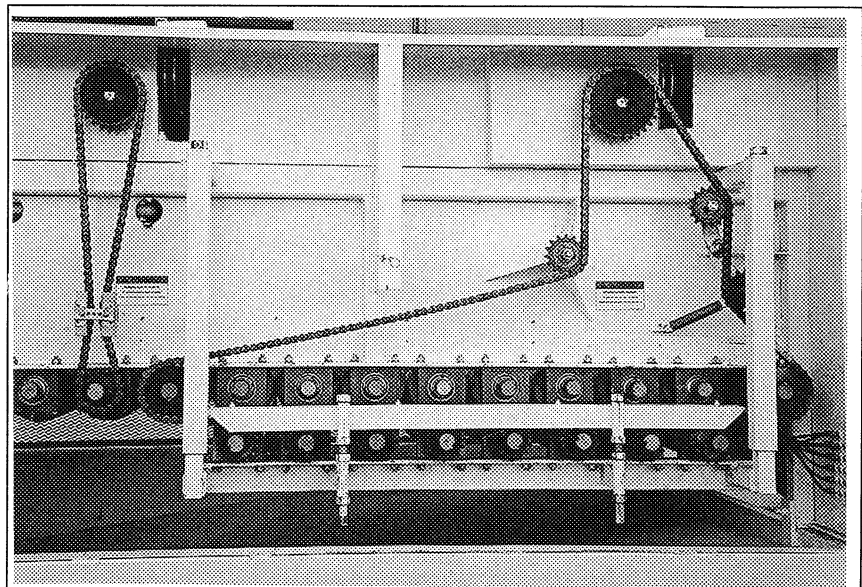
**Weekly or 50 Hours (cont'd)**

3. Grease the sponge roller shafts with one shot of grease (2 locations each shaft).

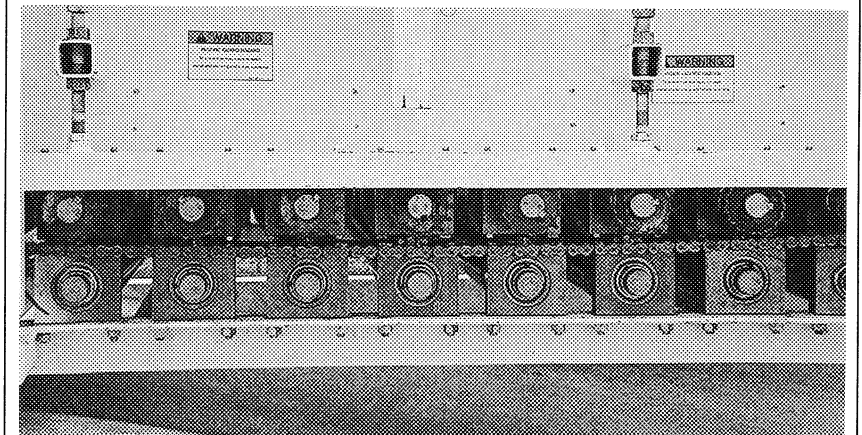


**Fig. 24 SPONGE ROLLER SHAFTS**

4. Grease the compression roller shafts with one shot of grease (2 locations each shaft).



**Left**

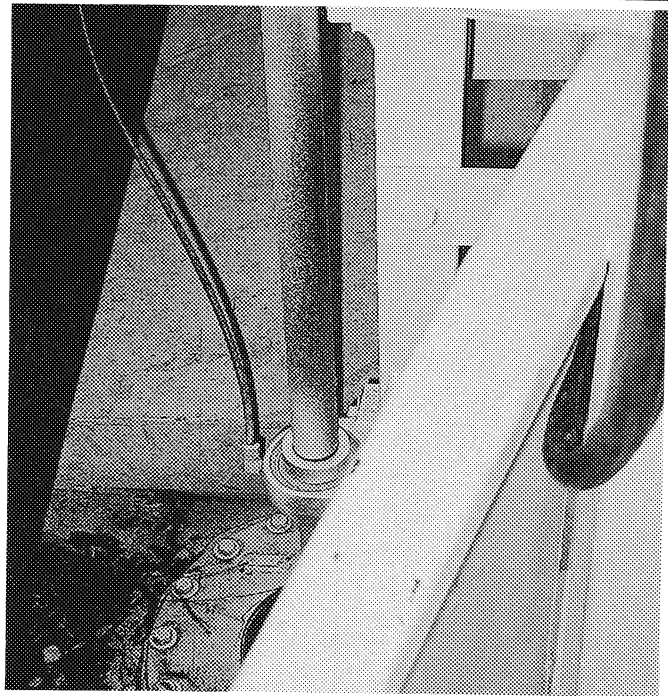


**Right**

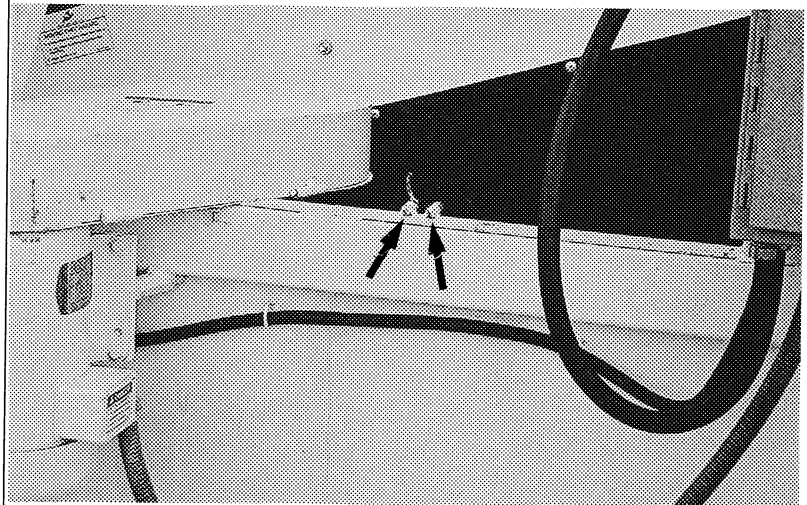
**Fig. 25 COMPRESSION ROLLER SHAFTS**

**Weekly or 50 Hours (cont'd)**

5. Grease trash pump drive bearings (2 locations).



**Bearings**

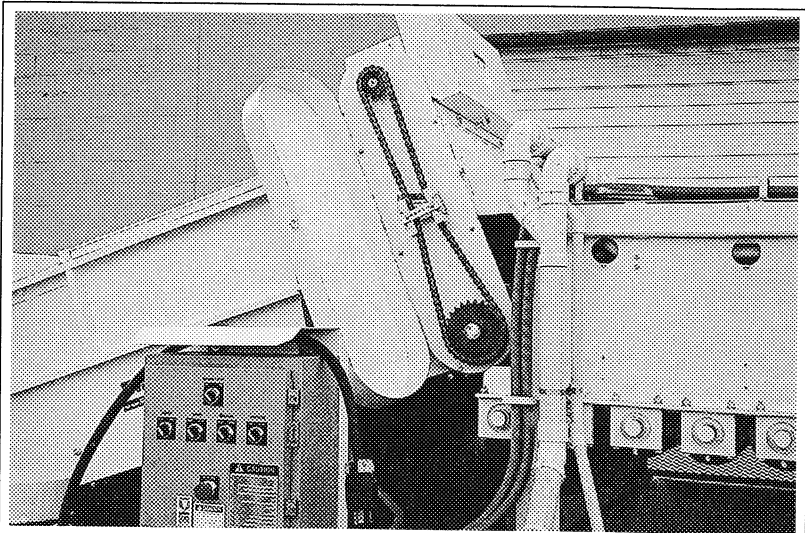


**Fittings**

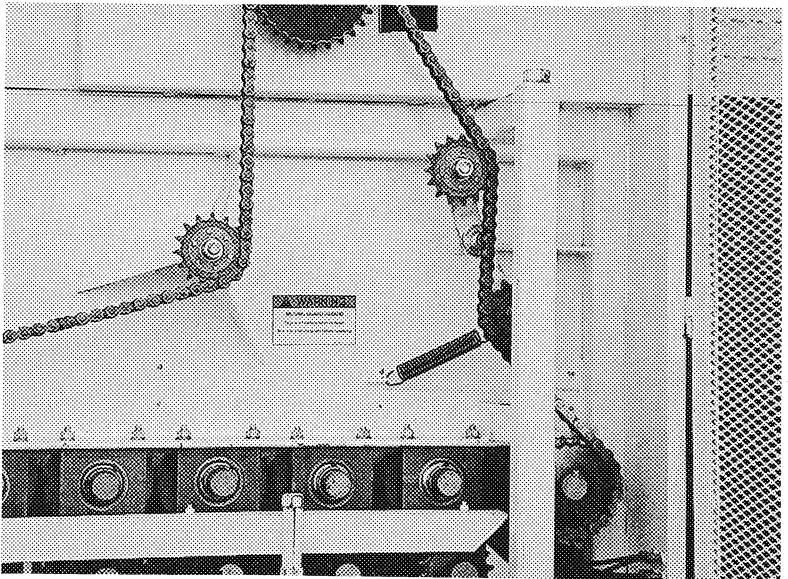
**Fig. 26 TRASH PUMP DRIVE**

**Weekly or 50 Hours (cont'd)**

6. Check the roller chain tension and sprocket alignment.



**Clamp**




**Tension Spring**

**Fig. 27 ROLLER CHAIN TENSION**

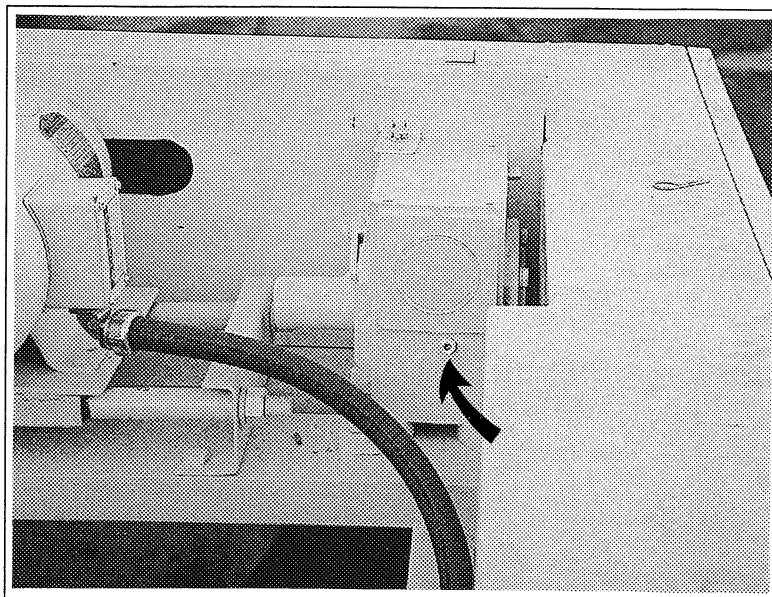


**Weekly or 50 Hours (cont'd)**

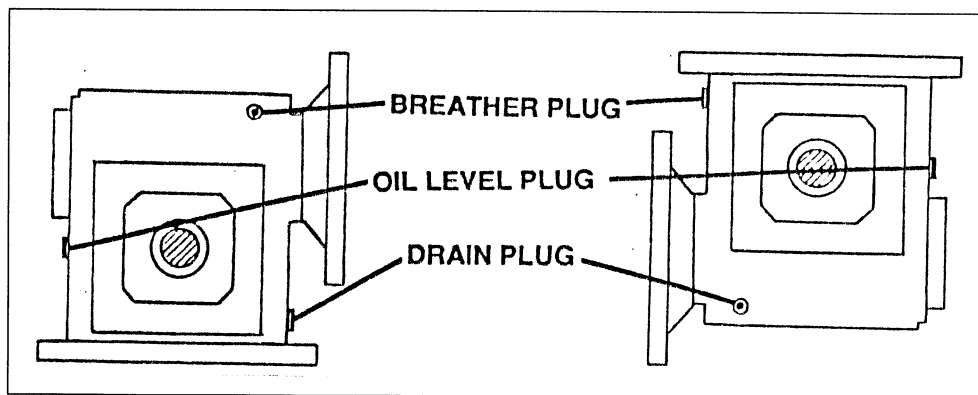
7. Check the oil level in each speed reducing gear box in the drive systems (1 location each gear box).

 **WARNING**

Machine is shown with guards opened for illustrative purposes only. Do not operate with guards opened.



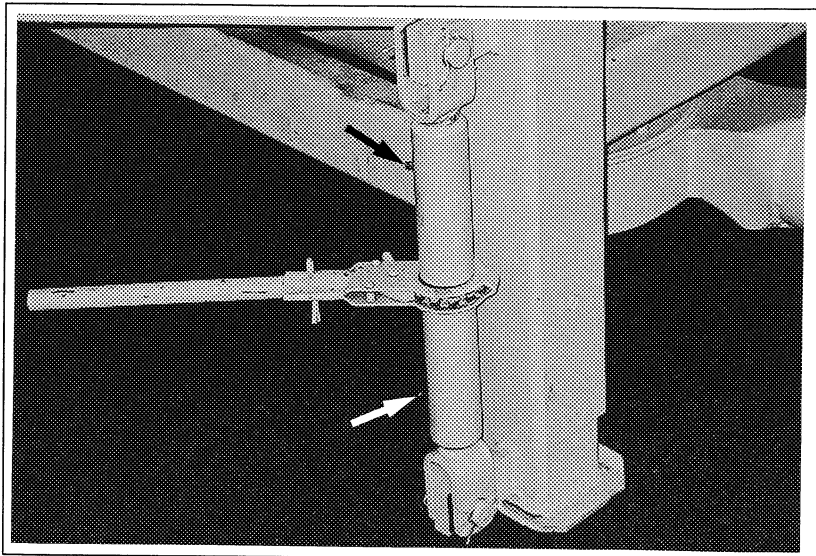
**Fig. 28 LEVEL PLUG**



**Fig. 29 GEAR BOX SCHEMATIC (TYPICAL)**

**200 Hours or Annually**

1. Grease the ratchet jacks (2 locations each jack).

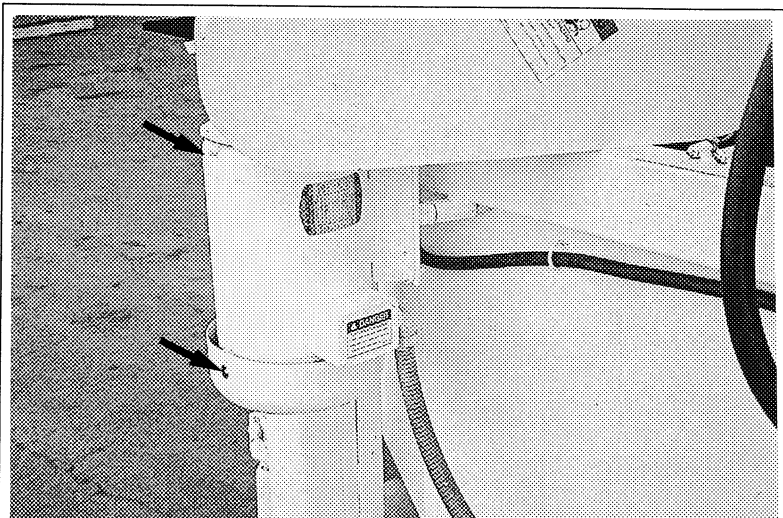


**Fig. 30 RATCHET JACK (TYPICAL)**

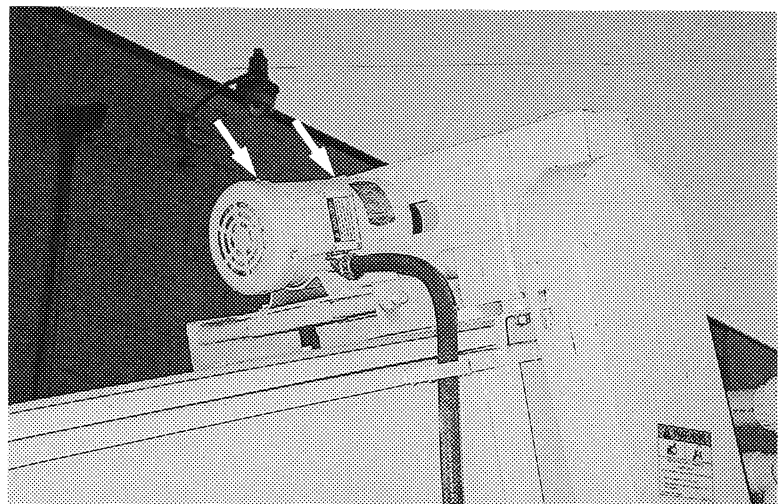
2. Grease the electric motor bearings with 1 shot of grease (2 locations each motor).

**IMPORTANT**

Do not over-grease electric motors. Over-greasing can render the electric motor inoperative.



**Trash Pump**




**Elevator Drive**

**Fig. 31 ELECTRIC MOTORS (TYPICAL)**

200 Hours or Annually (cont'd)

3. Change the oil level in each speed reducing gear box in the drive systems.

 **WARNING**

Machine is shown with guards opened for illustrative purposes only. Do not operate with guards opened.

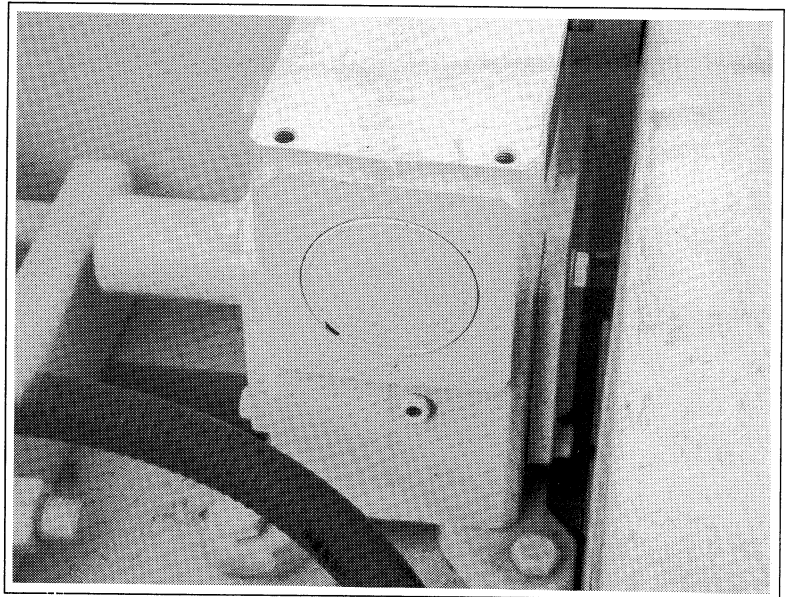


Fig. 32 GEAR BOXES (TYPICAL)

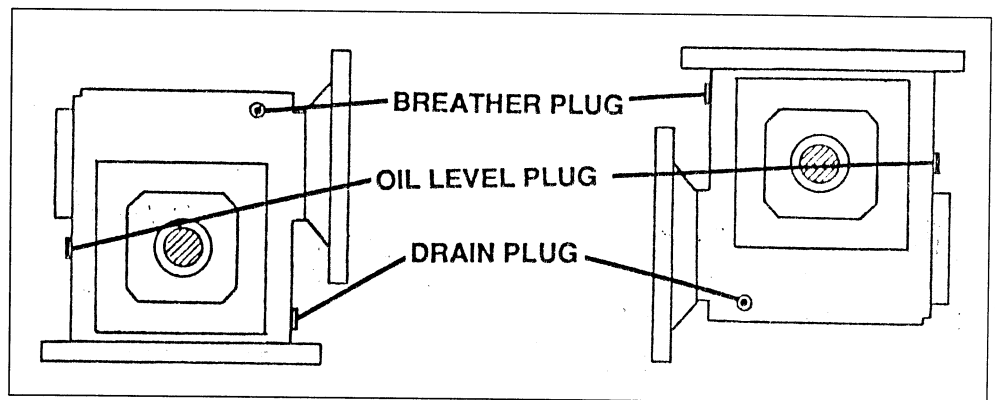
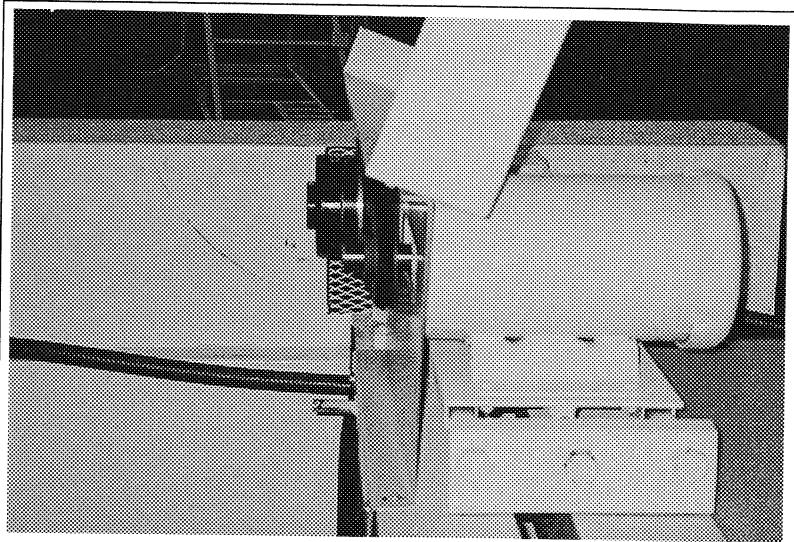


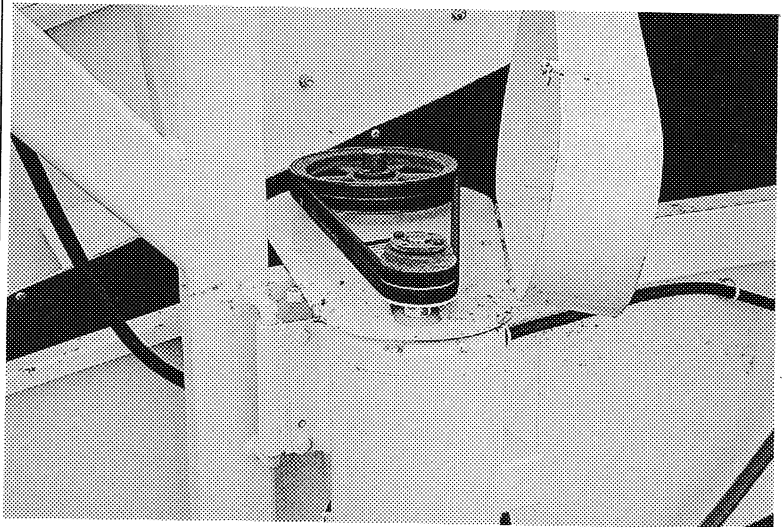
Fig. 33 GEAR BOX SCHEMATIC (TYPICAL)

200 Hours or Annually (cont'd)

4. Check the pulley alignment of the drive system.



**Brush Roller**

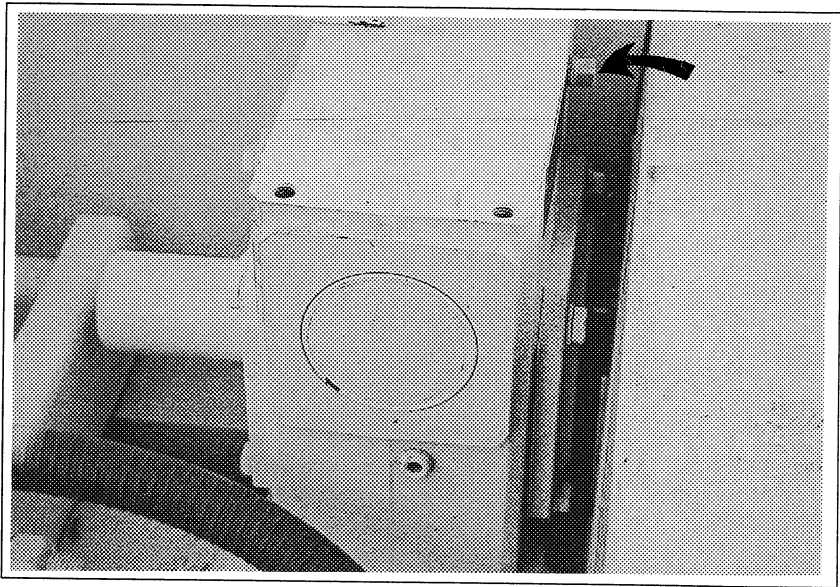


**Trash Pump**

**Fig. 34 PULLEY ALIGNMENT (TYPICAL)**

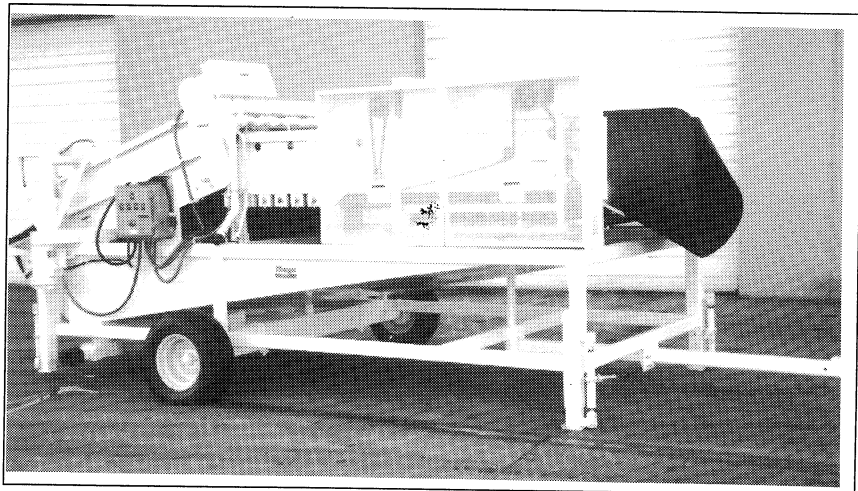
**200 Hours or Annually (cont'd)**

5. Clean each gearbox breather plug (1 plug each speed reducer).



**Fig. 35 BREATHER PLUG (TYPICAL)**

6. Repack each wheel bearing.



**Fig. 36 WHEELS (TYPICAL)**

### 5.1.4 SERVICE RECORD

See Lubrication and Maintenance sections for details of service. Copy this page to continue record.

ACTION CODE:    √ CHECK            C CHANGE            CL CLEAN            R REPACK  
                          L LUBRICATE        RE REMOVE        IN INSPECT

<div style="display: flex; justify-content: space-between;"> <span>HOURS</span> <span>SERVICED BY</span> </div> <div style="display: flex; justify-content: space-between;"> <span>MAINTENANCE</span> <span></span> </div>																				
	<b>8 Hours or Daily</b>																			
L Elevator Dr. Sys. Roller Chain																				
L Brush Roller Dr. Chain (2)																				
L Sponge Roller Dr. Chain (2)																				
√ Elevator Tension & Alignment																				
IN Water System & Components																				
IN Electrical Syst & Components																				
<b>Weekly or 50 Hours</b>																				
L Elevator Drive Shaft Bearings (2)																				
L Brush Roller Shafts (2 ea.)																				
L Sponge Roller Shafts (2 ea.)																				
L Compression Roller Shaft (2 ea.)																				
L Trash Pump Drive Bearings (2)																				
√ Roller Chain Tension																				
√ Sprocket Alignment																				
√ Oil Level Each Gearbox																				
<b>200 Hours or Annually</b>																				
L Ratchet Jacks (2 ea.)																				
L Electric Motor Bearings (2 ea.)																				
√ Oil Speed Reduce Gearboxes																				
√ Pulley Alignment of Dr. System																				
CL Each Gearbox Breather Plug																				
R Each Wheel Bearing																				

## 5.2 MAINTENANCE

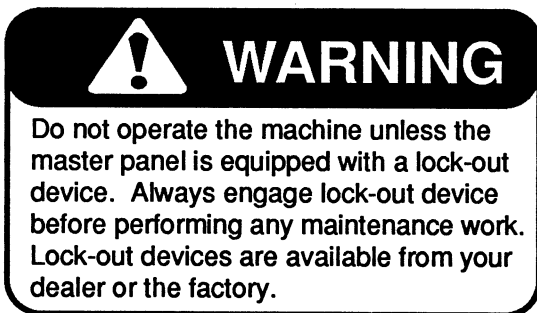
By following a careful service and maintenance program on your machine, you will enjoy many years of trouble-free use.

### 5.2.1 ELECTRICAL SYSTEM INSPECTION

Electricity provides power to all systems on the Washer. To maintain the integrity of each system and provide a safe working environment for the operator, it is important that a daily inspection be done to make sure that all systems and components are in good working condition. To provide a safe working environment, have a licensed electrician provide power to the machine.

When inspecting the electrical system and components, follow this procedure:

1. Place all controls in the OFF position.
2. Turn power OFF at the master panel and lock-out before starting the inspection.



3. Inspect all electrical components looking for:
  - a. Damaged plugs.
  - b. Frayed wires.
  - c. Cut or cracked insulation.
4. Replace any damaged components immediately.
5. Be sure all components are grounded.
6. Be sure there is no water or moisture in any junction box or enclosure. Dry the components before turning power on. Be sure that all compartments seal properly when closed.

## 5.2.2 ELECTRIC MOTOR RESTART

It is recommended that only a licensed electrician perform maintenance work on the electrical system.

All electric motors are supplied with power through an individual circuit that includes a circuit breaker, switch, contactor and overload relay that are all incorporated into a single electrical component inside the control panel. The contactor is the main connecting device for power to the motor. If the current is greater than the adjustable dial of the relay, the relay will trip and cut off power to the coil of the contactor. When this happens, the contactor dial will move to a new position and indicates the cause of the overload. It must be reset before the motor can be restarted.

When a motor will not start:

1. Turn the switch to its OFF position.
2. Turn the switch to its ON position.
3. If the motor will not start, turn machine OFF and lock out power at the master control panel before opening the control panel.
4. Turn the contactor dial counter-clockwise to the manual reset position. Then, turn the contactor dial clockwise to the ON contactor open position.
5. Close and secure the panel door and turn the power to the machine ON.
6. If the motor still will not start you have one of the following conditions:
  - a. The motor is hot and must cool a period of time before attempting to restart.

### NOTE

If your conveyor utilizes single phase motors, chances are good that the motor has a thermal overload located on the electrical junction box of the motor itself. If this is the case then, fully depress the reset button to make certain that the overload circuit is closed.

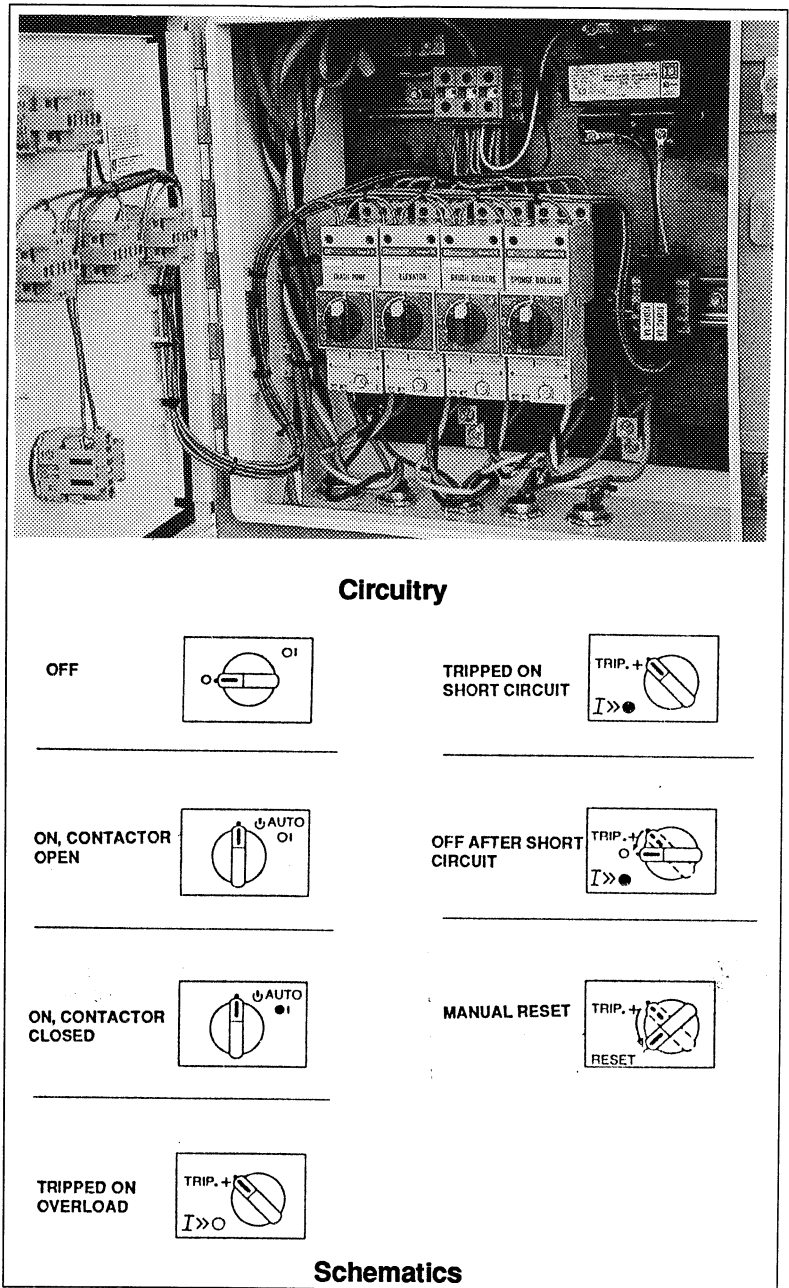


Fig. 37 MOTOR RESTART

- b. The overload is adjusted incorrectly for the amperage of the motor and must be properly adjusted.
- c. The overload and/or contactor has fulfilled its service life and is in need of replacement.
- d. The motor is bad and needs replacing.
- e. An electrical short exists somewhere in the circuit.



## 5.2.3 SPEED REDUCER GEARBOX OIL

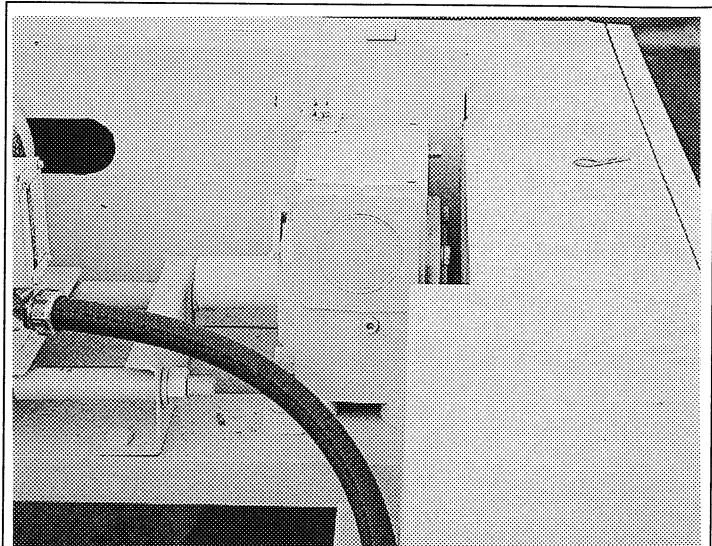
The optional elevator and rollers are driven by an electric motor that is attached to a high ratio speed reducing gearbox to give the required operating speed. Each gearbox is equipped with a drain, level and fill plug. Every 50 hours, the oil level should be checked. Every 200 operating hours or annually, whichever comes first, the oil should be replaced. Check more frequently if there are leaks around any of the plugs or shaft seals. When checking oil level or changing oil, follow this procedure.

1. Run the elevator and rollers until each gearbox is warm. Warm oil will remove more contaminants than cold stagnate oil.
2. Stop the drives.
3. Place all controls in their OFF position.
4. Turn the power OFF at the master panel and lock-out.
5. **Checking oil level:**
  - a. When the gearbox is cold, remove the level plug from the side of the gearbox.
  - b. When the oil just fills the threads of the level plug, it is at the correct level.
  - c. Add oil through the fill plug as required.
  - d. Install and tighten level and fill plugs.
6. **Changing oil:**
  - a. Place a container under the drain plug.
  - b. Remove the drain, level and fill plugs.
  - c. Allow 10 minutes to drain.
  - d. Install and tighten the drain plug.

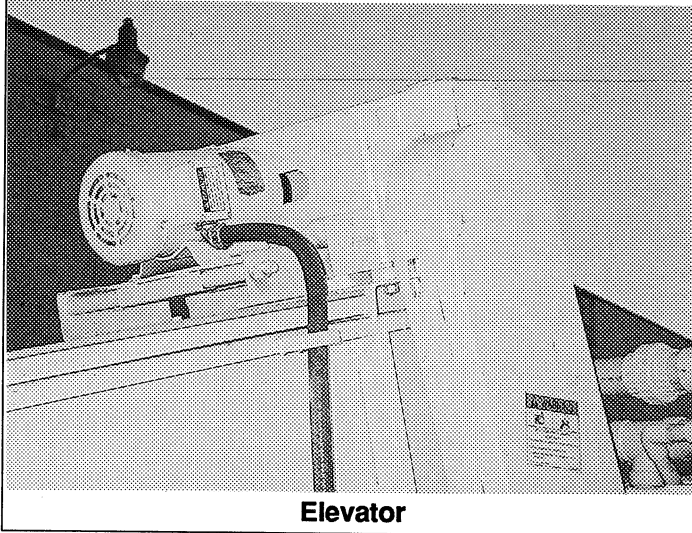
### NOTE

It may be necessary to add teflon tape or pipe sealant to the drain plug prior to installation to prevent leaking.

- e. Add Browning Worm Gear GL 32HT lubricant or equivalent. Use the level plug to determine the proper amount of oil.
- f. Check that the air passage through the breather is open.
- g. Install and tighten the fill and level plugs.
- h. Dispose of the used oil in an environmentally safe manner.



Roller Drive (Typical)



Elevator

Fig. 38 GEARBOXES (TYPICAL)



### WARNING

Machine is shown with guards opened for illustrative purposes only. Do not operate with guards opened.

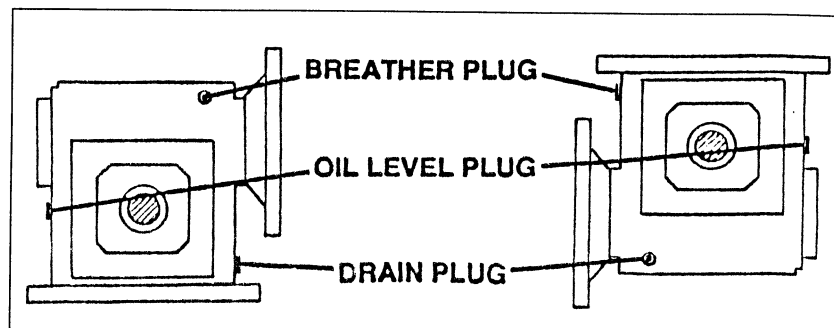


Fig. 39 GEARBOX SCHEMATIC (TYPICAL)

## 5.2.4 BREATHER CLEANING

Each gearbox is equipped with a breather in the fill plug that vents the internal pressure to atmosphere. As the gearbox temperature increases and decreases during the operating and stopped modes, the pressure in the gearbox will increase or decrease if it is not vented to atmosphere. An increase in internal pressure will cause the shaft seals to leak until the gearbox runs low on or out of oil. To check on or clean the breather, follow this procedure:

1. Place all controls in their OFF position.
2. Turn the power OFF at the master panel and lock-out.
3. Remove the fill plug/breather from the gearbox.
4. Check that the vent passage through the plug is open.
5. If plugged, soak in a solvent over night.
6. Use a high-pressure air hose to blow the passage open. Use a probe to clear the passage if the hole is caked with dirt.
7. Install and tighten the breather plug.

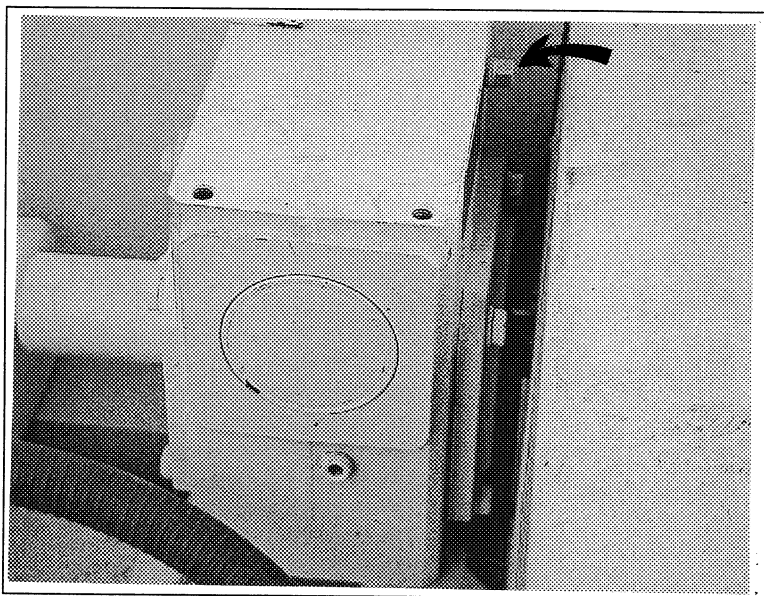


Fig. 40 BREATHER

### IMPORTANT

Always clean the breather if any leaks are noticed around shafts.



## WARNING

Machine is shown with guards opened for illustrative purposes only. Do not operate with guards opened.

## 5.2.5 OPTIONAL ELEVATOR CHAIN TENSION/ALIGNMENT OR REPLACEMENT

A potato chain is used on the optional elevator. The tension and alignment of the conveyor should be checked daily to insure proper function. Replace the conveyor chain when damaged or badly worn. To maintain conveyor, follow this procedure:

1. Place all controls in their OFF or neutral position.

2. Turn the power OFF at the master panel and lock-out.

3. **Tension:**

It is tensioned correctly when there is a 3 to 4 inch (75 to 100 mm) sag between the guide rollers on the bottom or slack side of the conveyor during operation.

4. **Alignment:**

It is properly aligned when the chain links center on the drive sprockets. If the links run on the side of the sprockets, align the chain. Align by loosening the shaft bearing assembly on the tight side or tightening the bearing assembly on the loose side. Move the bearing assemblies on the drive shaft but always maintain the proper tension.

5. **Replacement:**

a. Move the drive shaft into its loosest position.

b. Open the conveyor by splitting the links on the chain.

c. Attach the replacement chain to the end of the old chain.

d. Slowly pull the old chain out of the machine and thread the new one into position.

e. Disconnect the old chain and connect the ends of the new one together.

f. Move the shaft into position to set the tension of the chain and secure the bearing assemblies.

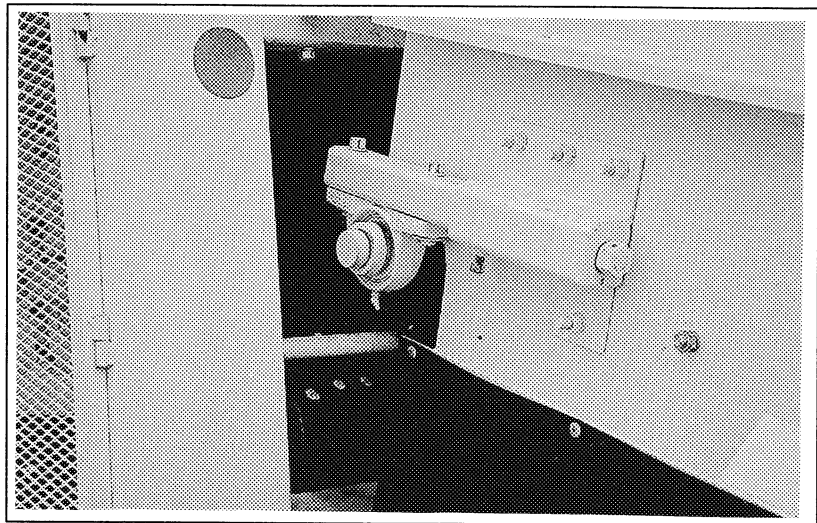


Fig. 41 TENSION ADJUSTING (TYPICAL)



### WARNING

Machine is shown with guards opened for illustrative purposes only. Do not operate with guards opened.

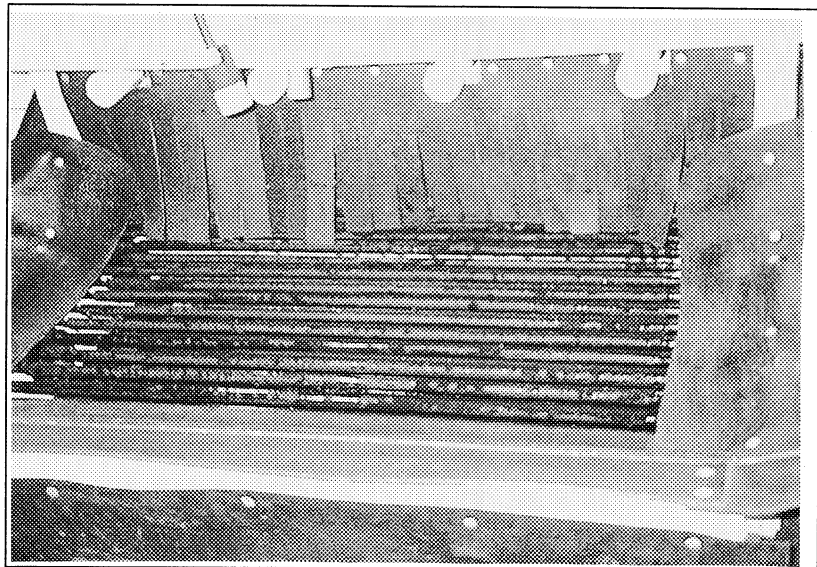


Fig. 42 CHAIN ALIGNMENT

g. Check the tension and alignment of the chain frequently during the first 10 hours of operation and set as required. Then, go to the regular maintenance schedule. Normally a conveyor will seat itself during the first 10 hours of operation and then require less adjustment.

## 5.2.6 ROLLER CHAIN DRIVES

The elevator and rollers are driven by a roller chain system with sprockets and an idler or a tightening system. The roller chain must be oiled on a daily basis and the tension and alignment checked weekly during the season. When maintaining the roller chain, follow this procedure:

### 1. Daily Oiling:

- a. Open the guards over the elevator and roller drive systems.
- b. Use an oil can or brush to apply oil to the slack side of the chain.



## WARNING

Use special care when working around exposed moving parts.

- c. Refer to the following table for oil type.

CHAIN TYPE *	AMBIENT TEMPERATURE RANGE		
	14°F - 32°F	32°F - 104°F	104°F - 122°F
RS-50-less	SAE 10	SAE 20	SAE 30
RS-60/RS-80	SAE 20	SAE 30	SAE 40
RS100	SAE 20	SAE 30	SAE 40
RS120/MORE	SAE 30	SAE 40	SAE 40

\* Stamped on chain link side plate

- d. Close and secure all the guards.

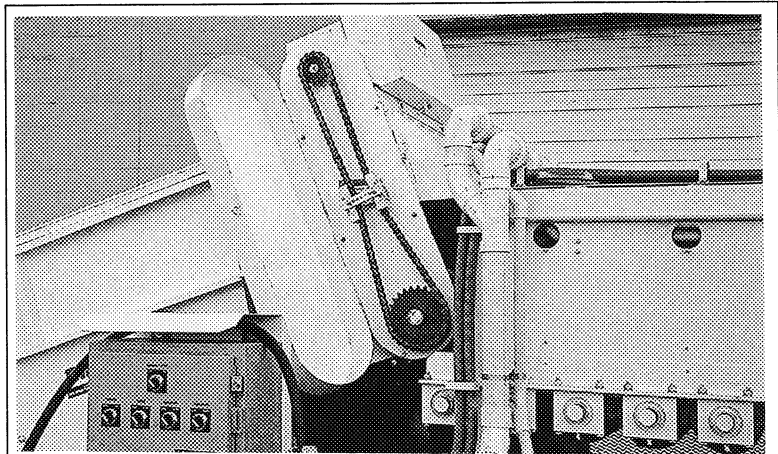
### 2. Weekly Sprocket Alignment:

- a. Check alignment by:
  - i. Lay a straight edge across the faces of the sprockets. When the straight edge is flush with the faces of the sprockets, they are aligned, or
  - ii. Visually sight across the faces of the sprockets. If sprockets are in the same plane they are aligned.
- b. Loosen set screw in sprocket hub if alignment is required.
- c. Move sprocket to required position.
- d. Tighten set screw(s) to their specified torque.
- e. Close and secure all the guards.

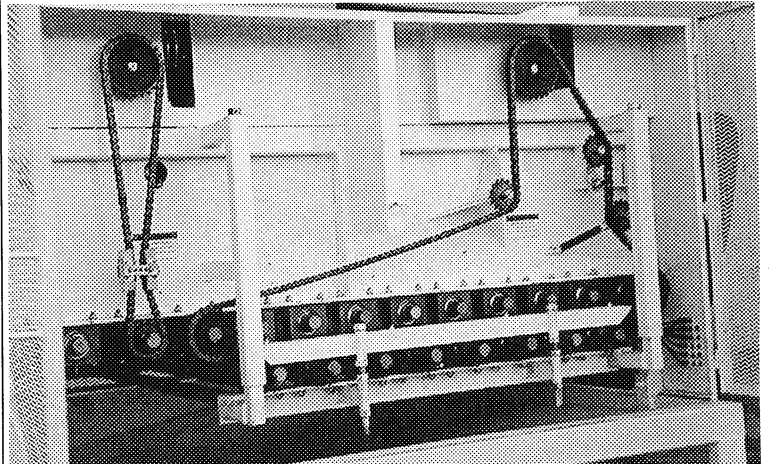


## WARNING

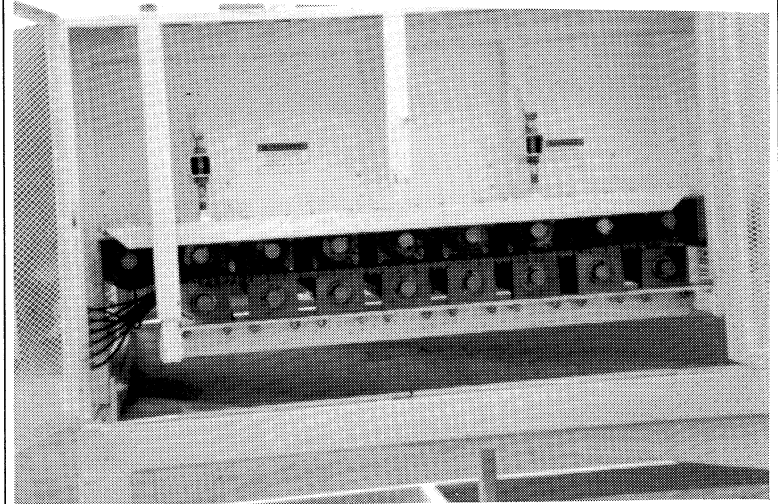
Machine is shown with guards opened for illustrative purposes only. Do not operate with guards opened.



Elevator



Brush And Compression



Sponge Roller

Fig. 43 ROLLER CHAIN DRIVES

## 5.2.6 ROLLER CHAIN DRIVES (cont'd)

### 3. Weekly Roller Chain Tension:

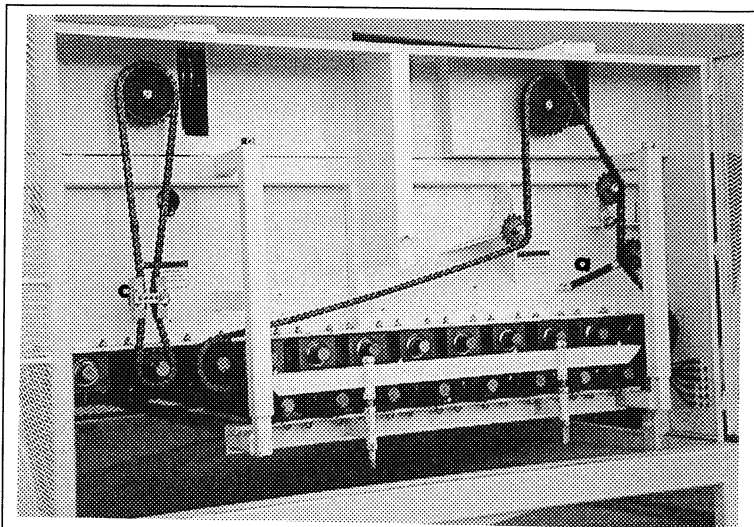
Each roller chain drive system is equipped with a spring-loaded idler sprocket or tension device to maintain the required tension on the chain during operation. Check the idler when the machine is OFF and not moving. There should be some tension on the spring attached to the idler sprocket when the machine is at rest. Without spring tension when stopped, there will not be sufficient tension on the system during operation. Provide spring tension by:

- a. Check the condition of the spring itself. If it has a permanent set, it has reached the end of its useful life and must be replaced.
- b. Shorten the roller chain itself by removing a half link, full link or more until the spring is under tension.
- c. Shorten the roller chain itself by removing a half link, full link or more until tension device again properly tensions the chain.

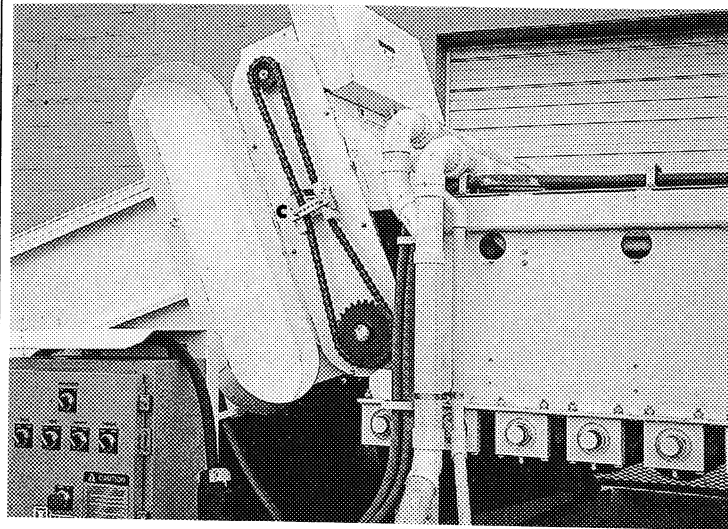


### WARNING

Turn power OFF at the master panel and lock-out before performing any maintenance work.



Roller - Primary



Elevator

Fig. 44 CHAIN TENSION

## 5.2.7 TRASH PUMP BELT DRIVE

Power to the trash pump is routed through a V belt system. The drive must be maintained with the proper belt tension and pulley alignment to obtain the desired performance and life. When maintaining the drive system, follow this procedure:

1. Place all controls in their OFF or neutral position.
2. Turn the power OFF at the master panel and lock-out.
3. Open guard over belt drive system.
4. **Belt Tension:**
  - a. Push on the center of the belt span with a force of approximately 5 lbs.
  - b. The belt will deflect approximately 1/4 to 1/2 inch (6-12 mm) when properly tensioned.
  - c. Loosen the jam nut on the motor assembly position bolt.
  - d. Use the position bolt to move the motor assembly to the required position to properly tension the belt.
  - e. Tighten jam nut to its specified torque.

### NOTE

Use a matched set of replacement belts for the best results.

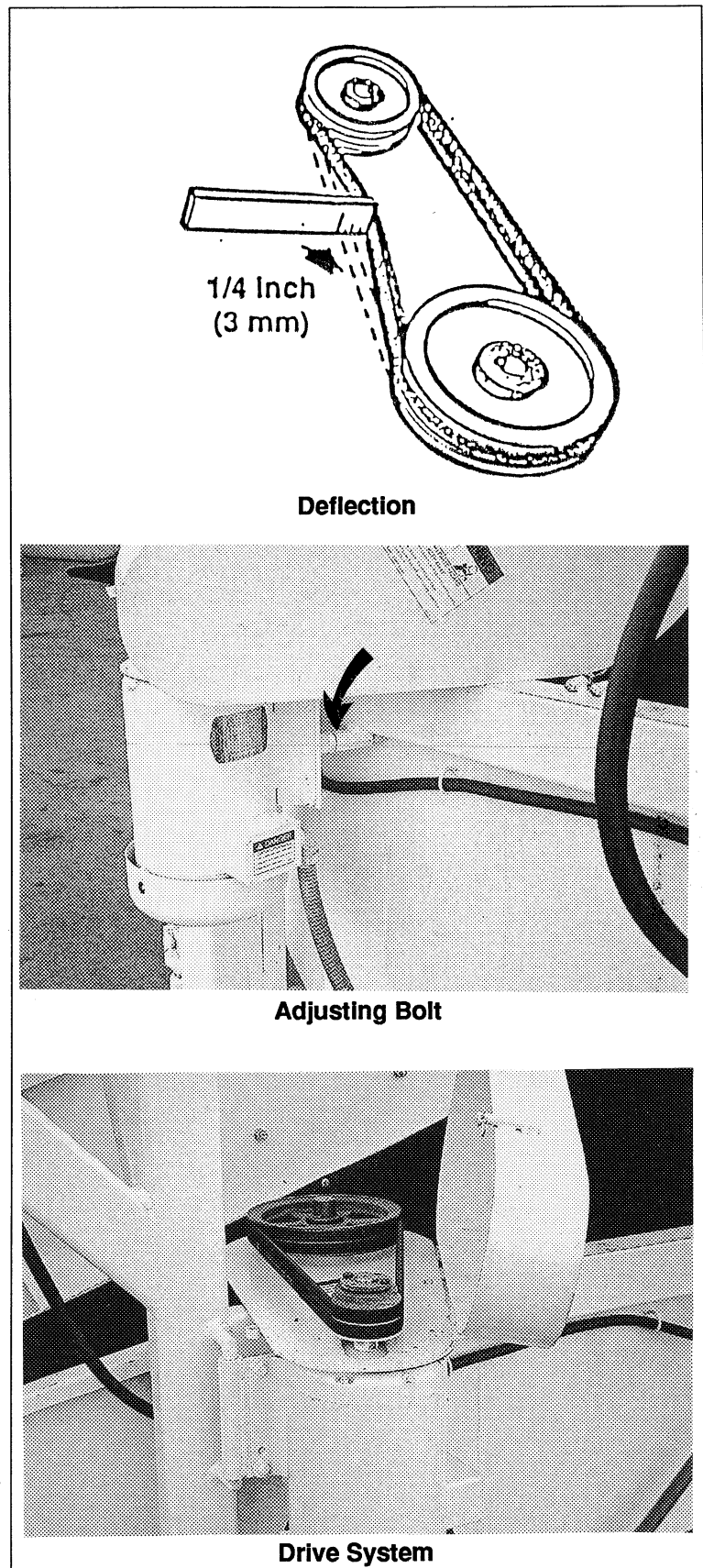


Fig. 45 TRASH PUMP BELT DRIVE

## 5.2.7 TRASH PUMP BELT DRIVE (cont'd)

### 5. Pulley Alignment:

- a. Lay a straight edge across the face of pulleys to check the alignment.
- b. If the pulley faces are more than 1/16 inch (1.5 mm) from the straight edge, the pulleys must be aligned.
- c. Loosen hub bolts on drive pulley.
- d. Move pulley to desired position.
- e. Tighten hub bolts to their specified torque.

### 6. Belt Replacement:

- a. Place motor assembly in its loosest position.
  - b. Remove old belt and install a new one.
  - c. Move the motor into position with the pulleys aligned and the belt tension properly set.
  - d. Tighten position bolt jam nut to its specified torque.
  - e. Check and adjust the tension and alignment frequently during the first 10 hours of operation until the belt is broken-in.
7. Close and secure the guard.

## 5.2.8 COMPRESSION ROLLER SPACING

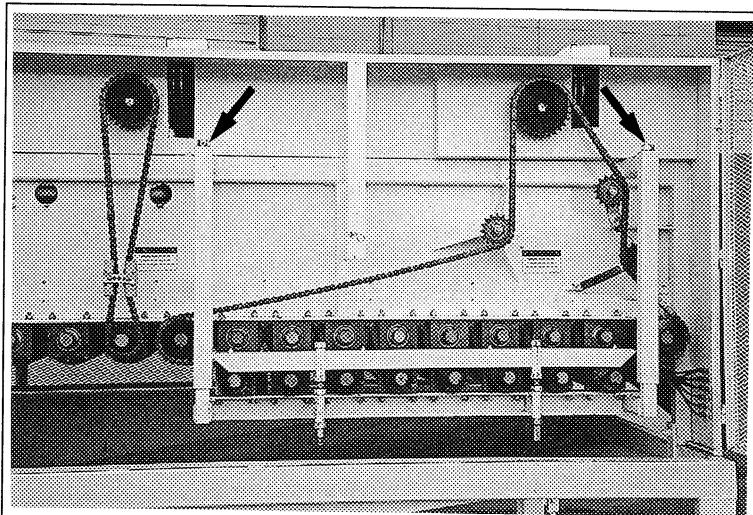
Compression rollers are located under the sponge rollers to remove excess moisture from the sponge rollers as the system turns. Check the compression dimension on a weekly basis. When checking and setting the sponge compression dimension, follow this procedure:

1. Place all controls in their OFF position.
2. Turn the power OFF at the master panel and lock-out.
3. Open the guards over the compression rollers.
4. Measure the thickness of the sponge where the compression roller contacts and does not contact the sponge. This compression dimension should not exceed 1/4 inch (6 mm).
5. Use the threaded rods on corners of the compression roller assembly to set the compression dimension.
6. Close and secure guards.

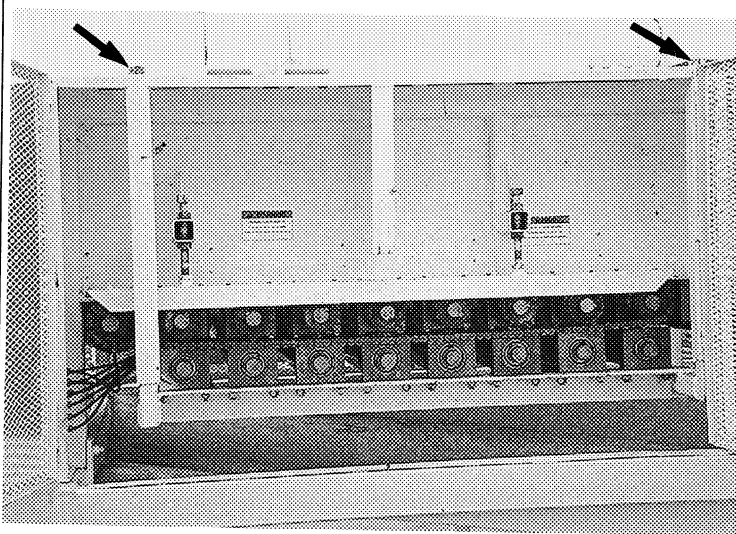


### WARNING

Machine is shown with guards opened for illustrative purposes only. Do not operate with guards opened.



Adjustment - Left



Adjustment - Right

Fig. 46 COMPRESSION ROLLERS



## 5.2.9 ROLLER DRIVES

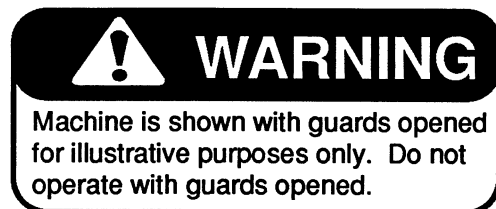
Roller chains are used to transmit power to each of the brush, sponge and compression rollers. Maintain the proper spacing between the sprocket and the backing channel to prevent skipping or jumping by the chain. When maintaining the roller drive, follow this procedure:

1. Place all controls in the OFF position.
2. Turn the power OFF at the master panel and lock out.
3. Open guards over the roller drives.
4. Loosen the channel position bolt jam nuts.
5. Use the position bolt to move the channel to the required position.

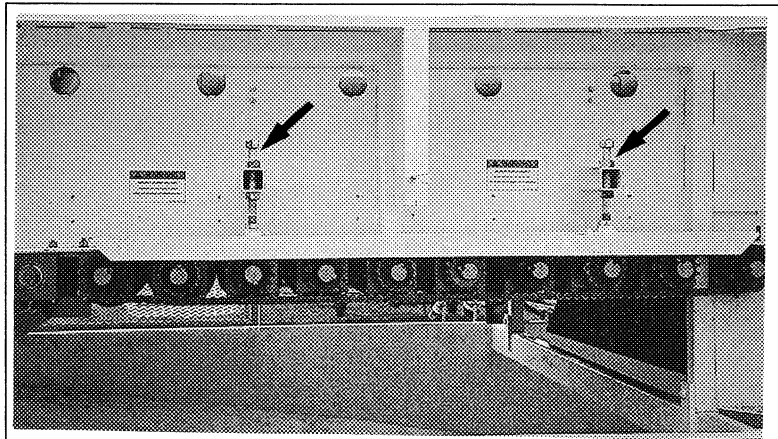
### NOTE

The chain connecting links must be able to move between the channel and the sprocket without binding. Do not move the channel too close to the sprockets.

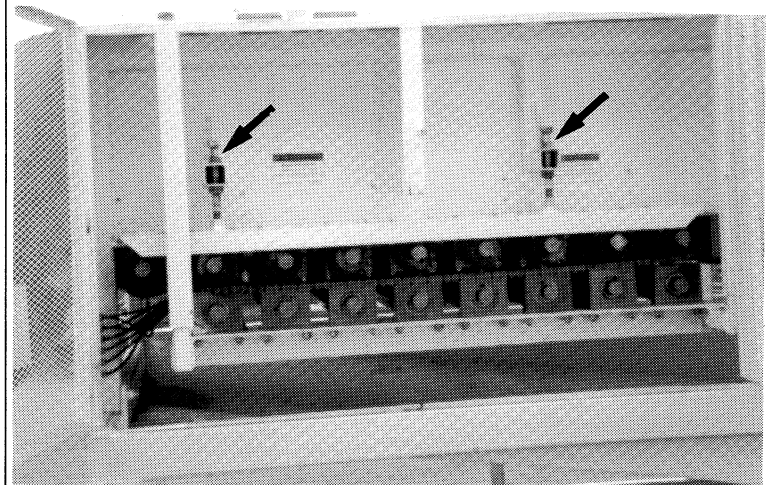
6. Tighten jam nuts to their specified torque.



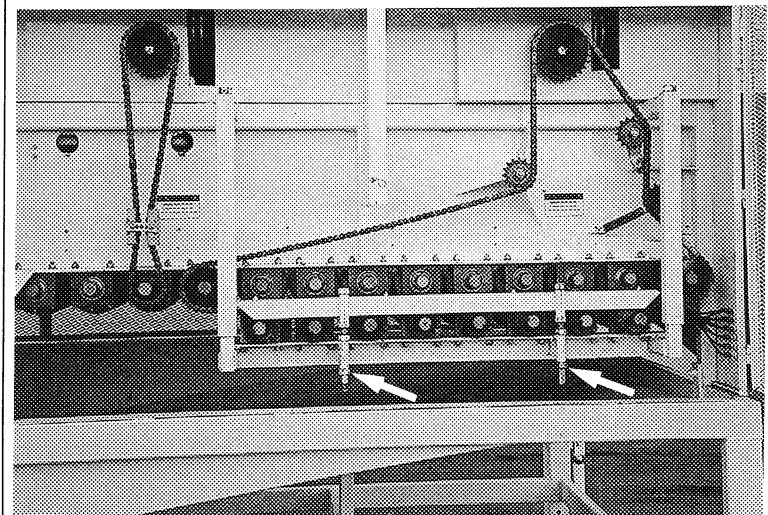
7. Close and secure the guards.



Brush Roller



Sponge Roller



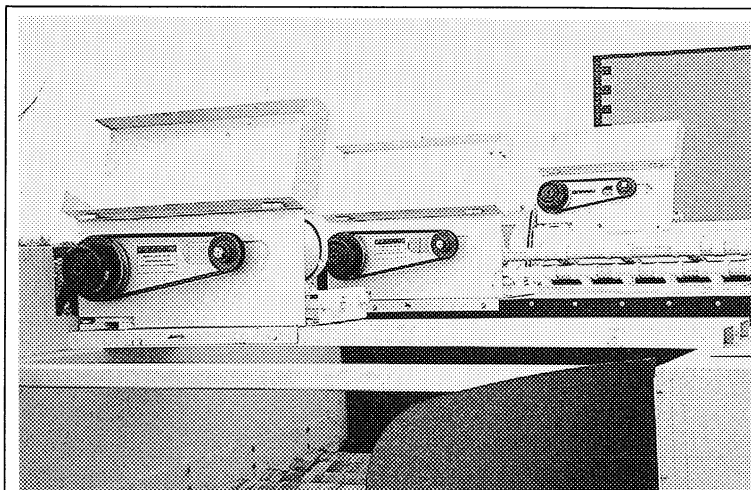
Compression Roller

Fig. 47 BACKING CHANNEL POSITION BOLTS

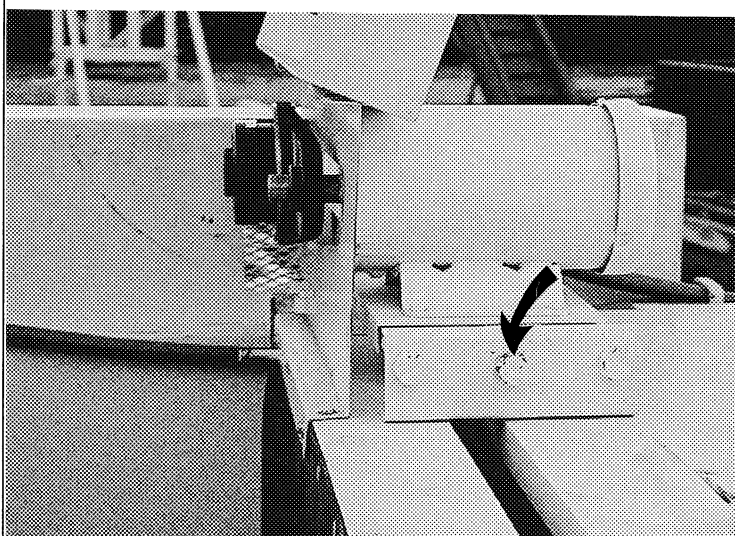
## 5.2.10 SYSTEM SPEEDS - DRIVE BELT

The elevator and roller drive systems are designed with a variable sheave V-belt for setting the operating speed of the system. The speed is set from the factory in the middle of its operating rate. To set the system speed, follow this procedure:

1. Place all controls in their OFF position.
2. Turn the power OFF at the master panel and lock-out before performing any maintenance work.
3. Move the motor assembly to set the operating speed. The spring-loaded variable sheave drive pulley will adjust and maintain the required belt tension.
4. Open the guard over the drive system.
5. Move the pulleys closer together to increase operating speed and apart to decrease.
6. Close and secure guard.



**Belt Drives**



**Adjustment (Typical)**

**Fig. 48 DRIVE BELT SPEED ADJUSTMENT**



### **WARNING**

Machine is shown with guards opened for illustrative purposes only. Do not operate with guards opened.

## 6 TROUBLE SHOOTING

The Mayo Washer uses a flow of water through to soak and scrub potatoes and then remove excess water as the potatoes move through the machine. It is a simple and reliable system that requires minimum maintenance.

In the following section, we have listed many of the problems, causes and solutions to the problems that you may encounter.

If you encounter a problem that is difficult to solve, even after having read through this trouble shooting section, please contact your local Mayo dealer or the factory. Before you call, please have this Operator's Manual and the serial number from your machine ready.

<b>PROBLEM</b>	<b>CAUSE</b>	<b>SOLUTION</b>
Washer won't run.	No power.	Plug machine in. Turn power ON at master panel.
	Tripped circuit breaker.	Reset circuit breaker.
Elevator or rollers won't run.	No power.	Plug machine in. Turn elevator or rollers ON.
	Tripped motor starter.	Reset starter.
	Failed drive chain.	Replace drive chain if broken. Install chain on sprockets and set tension.
	Elevator binding.	Align elevator.
No water.	No power.	Plug water recycler in. Turn recycler ON.
	Leak in water system.	Fix leak in system.
	Water level too low in recycler.	Fill to adequate level.
Trash pump not running.	No power.	Turn pump ON.
	Belt slipping.	Replace or tighten belt.
	Tripped motor starter.	Reset starter.
Potatoes not clean.	Dirt not soaked loose.	Slow elevator speed to provide long pre-soak time.
	Insufficient scrubbing.	Slow elevator speed to reduce number of potatoes on brush rollers.  Increase brush roller speed to increase scrubbing action.
	Wash water dirty.	Replace wash water with clean water.
	No final wash.	Turn fresh water supply ON.
	Sponge rollers not clean.	Wash and clean sponge rollers.
Potatoes not dry.	Sponge rollers not dry.	Move compression rollers into sponge rollers to dry sponge.
	Sponge rollers running too fast.	Slow sponge roller speed.

# 7 SPECIFICATIONS

## 7.1 MECHANICAL

DIMENSIONS	Washer/Sponger		Optional Elevator/Washer/Sponger	
	W/Hitch	W/O Hitch	W/Hitch	W/O Hitch
Length:	12'4"	10'9"	23'3"	20'3"
Width:		10'4"		10'4"
Height:		6'11"		6'11"
<b>POWER</b>				
Type	1 ph, 230v, 78a 3 ph, 230v, 42a			
Trash Pump:	5 HP			
Elevator:	3 HP			
Brush Roller:	3 HP			
Sponge Roller:	3 HP			
<b>WASH WATER SYSTEM</b>				
Flow:	200 GPM			
Pressure:	35-40 psi			
<b>FRESH WATER SYSTEM</b>				
Flow:	3 gpm			
Pressure:	35-40 psi			
<b>TIRES</b>				
Size:	7.60-15			
Pressure:	30 psi			

**SPECIFICATIONS SUBJECT TO CHANGE WITHOUT NOTICE**

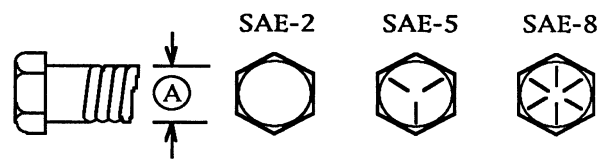
## 7.2 BOLT TORQUE

### CHECKING BOLT TORQUE

The tables shown below give correct torque values for various bolts and capscrews. Tighten all bolts to the torques specified in chart unless otherwise noted. Check tightness of bolts periodically, using bolt torque chart as a guide. Replace hardware with the same strength bolt.

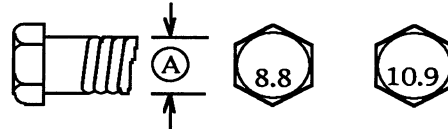
#### ENGLISH TORQUE SPECIFICATIONS

Bolt Diameter "A"	Bolt Torque*					
	SAE 2 (N.m) (lb-ft)		SAE 5 (N.m) (lb-ft)		SAE 8 (N.m) (lb-ft)	
1/4"	8	6	12	9	17	12
5/16"	13	10	25	19	36	27
3/8"	27	20	45	33	63	45
7/16"	41	30	72	53	100	75
1/2"	61	45	110	80	155	115
9/16"	95	60	155	115	220	165
5/8"	128	95	215	160	305	220
3/4"	225	165	390	290	540	400
7/8"	230	170	570	420	880	650
1"	345	225	850	630	1320	970



#### METRIC TORQUE SPECIFICATIONS

Bolt Diameter "A"	Bolt Torque*			
	8.8 (N.m) (lb-ft)		10.9 (N.m) (lb-ft)	
M3	.5	.4	1.8	1.3
M4	3	2.2	4.5	3.3
M5	6	4	9	7
M6	10	7	15	11
M8	25	18	35	26
M10	50	37	70	52
M12	90	66	125	92
M14	140	103	200	148
M16	225	166	310	229
M20	435	321	610	450
M24	750	553	1050	774
M30	1495	1103	2100	1550
M36	2600	1917	3675	2710

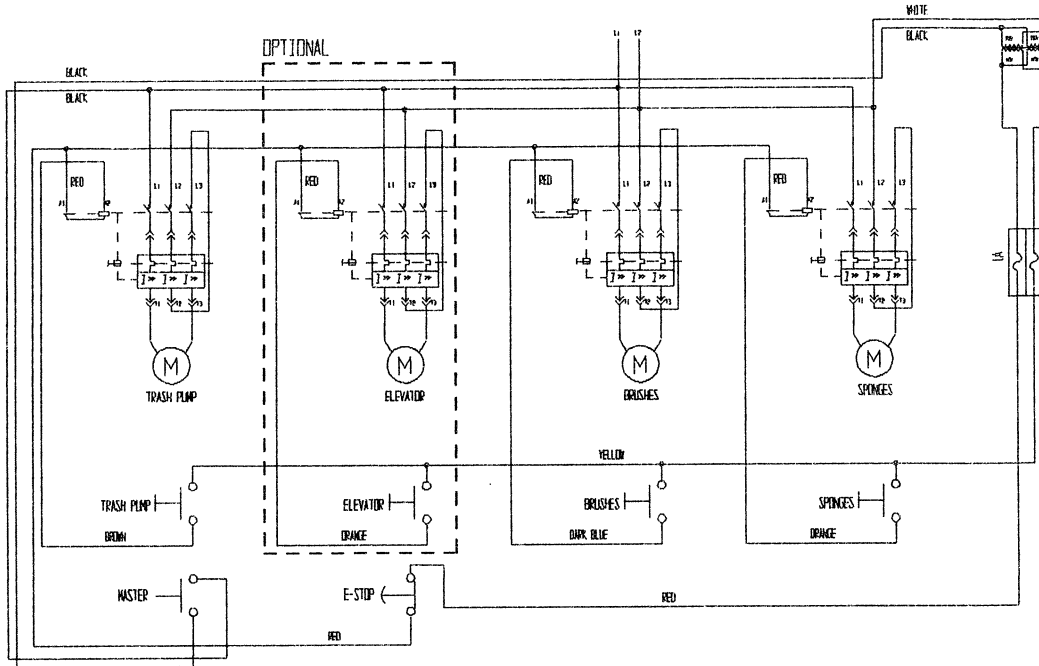


Torque figures indicated above are valid for non-greased or non-oiled threads and heads unless otherwise specified. Therefore, do not grease or oil bolts or capscrews unless otherwise specified in this manual. When using locking elements, increase torque values by 5%.

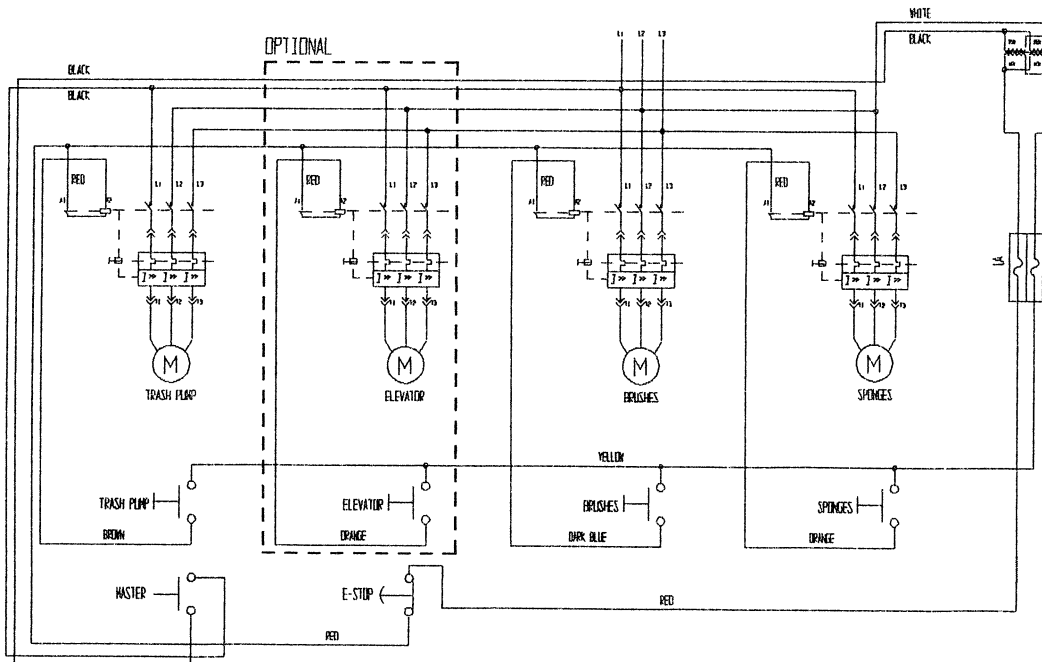
\* Torque value for bolts and capscrews are identified by their head markings.

# 7.3 ELECTRICAL SCHEMATIC

## PORTABLE WASHER/SPONGER (TYPICAL) SINGLE PHASE



## PORTABLE WASHER/SPONGER (TYPICAL) THREE PHASE



# 8 INDEX

	PAGE		PAGE
		<b>I</b>	
Introduction .....	1		
		<b>O</b>	
Operation .....	12		
Controls .....	16		
Brush Rollers STOP/START .....	16		
Elevator STOP/START .....	16		
Emergency STOP Control .....	16		
Master OFF/ON .....	16		
Sponge Rollers STOP/START .....	16		
Trash Pump STOP/START .....	16		
General Operation Theory .....	14		
Machine Break-In .....	15		
Machine Components .....	13		
Machine Preparation .....	17		
Operating .....	19		
Auxiliary Equipment .....	21		
Bruising .....	24		
Emergency Stop .....	20		
Machine Speed .....	21		
Moving .....	21		
Nozzles .....	22		
Operating Hints .....	24		
Review and Follow Sections 4.5-4.7 ...	19		
Rollers .....	23		
Starting Washer .....	20		
Stopping Machine .....	20		
Water Quality .....	24		
Water Supply .....	19		
Pre-Operation Checklist .....	15		
Storage .....	26		
Placing In Storage .....	26		
Removing From Storage .....	26		
To The New Operator or Owner .....	12		
Transport .....	25		
		<b>S</b>	
Safety .....	2		
General Safety .....	3		
Installation Safety .....	4		
Maintenance Safety .....	5		
Operating Safety .....	4		
Electrical Safety .....	5		
Employee Sign-Off Form .....	7		
Safety Signs .....	6		
Storage Safety .....	6		
Tire Safety .....	5		
Transport Safety .....	6		
Safety Sign Locations .....	8		
Service and Maintenance .....	27		
Maintenance .....	41		
Breather Cleaning .....	44		
Compression Roller Spacing .....	50		
Electrical Motor Restart .....	42		
Electrical System Inspection .....	41		
Optional Elevator Chain Tension/ Alignment or Replacement .....	45		
Roller Chain Drives .....	46		
Roller Drives .....	51		
Speed Reducer Gearbox Oil .....	43		
System Speeds - Drive Belt .....	52		
Trash Pump Belt Drive .....	48		
Service .....	27		
Fluids and Lubricants .....	27		
Greasing .....	27		
Service Record .....	40		
Servicing Intervals .....	28		
Specifications .....	54		
Bolt Torque .....	55		
Electrical Schematic .....	56		
Mechanical .....	54		
		<b>T</b>	
Trouble Shooting .....	53		

**MAYO MANUFACTURING, INC.**  
**P.O. BOX 497, BUS. HIGHWAY 2**  
**EAST GRAND FORKS, MINNESOTA**  
**56721**  
**PHONE (218) 773-1234**  
**(800) 223-5873**  
**FAX (218) 773-6693**