

# Mayo



**RAIL CAR LOADER**  
**Model 920**  
**OPERATOR'S MANUAL**

## **MAYO MANUFACTURING, INC. LIMITED WARRANTY**

THE FOLLOWING WARRANTIES FOR MACHINERY, EQUIPMENT OR PARTS SOLD BY MAYO MANUFACTURING, INC. ARE IN LIEU OF ALL OTHER WARRANTIES, EXPRESSED OR IMPLIED, OR THOSE WARRANTIES IMPOSED BY STATUE, INCLUDING, BUT NOT LIMITED TO ANY AND ALL IMPLIED WARRANTIES OR MERCHANTABILITY AND FITNESS FOR A PARTICULAR PURPOSE AND OF ANY AND ALL OTHER WARRANTY OBLIGATIONS ON THE PART OF MAYO MANUFACTURING, INC. (The Company).

The Company warrants the machinery, equipment or parts delivered against faulty workmanship or the use of parts delivered against faulty workmanship or the use of defective materials for a period of one (1) year from the date of shipment.

The Company's warranties set forth above are the only warranties made by the Company and shall not be enlarged, diminished or affected by, and no obligation or liability shall arise out of the Company's rendering technical or other advice or service in connection with the machinery, equipment or parts.

Parts or components furnished to the Company by third persons are guaranteed only to the extent of the original manufacturer's guarantee to the Company, a copy of which will be supplied to the Purchaser upon written request to the Company.

### **LIABILITY**

THE COMPANY'S SOLE AND EXCLUSIVE MAXIMUM LIABILITY, AND PURCHASER'S SOLE AND EXCLUSIVE REMEDY under the above warranty shall be, at the Company's option, the repair, or replacement of the machine, equipment or part which is found to be defective due to faulty workmanship or defective materials, and is returned by the Purchaser to the Company within the warranty period. Shipment both ways and in transit damage shall be at the purchaser's risk and expense. If the Company elects to repair or replace the machine, equipment, or part, the Company will have a reasonable time within which to do so.

The remedies set forth above are available upon the following conditions:

1. Purchaser has promptly notified Company upon discovery that the machinery, equipment, or parts are defective due to faulty workmanship or defective materials; and
2. Purchaser provides Company with a detailed description of the deficiencies; and
3. Company's examination discloses that the alleged deficiencies exist and were not caused by accident, fire, misuse, neglect, alteration, or any other hazard or by Purchaser's improper installation, use or maintenance.

Such repair or replacement shall constitute fulfilment of all Company's liability to Purchaser, whether based on contract or tort.

This warranty does not apply to any machine that has been altered outside the factory in any way so as, in the judgement of Mayo, to affect its operation, reliability or safety, or which has been subject to misuse, neglect or accident.

In the event the Company breach any other provisions of the Purchase Agreement, the Company's EXCLUSIVE MAXIMUM LIABILITY AND PURCHASER'S EXCLUSIVE REMEDY, whether in contract or tort, otherwise shall not in any event exceed the contract price for the particular machine, piece of equipment or parts involved.

IN NO EVENT SHALL COMPANY BE LIABLE TO ANYONE FOR SPECIAL, COLLATERAL, INCIDENTAL, OR CONSEQUENTIAL DAMAGES FOR BREACH OF ANY PROVISIONS OF THIS CONTRACT OR WARRANTY. SUCH EXCLUDE DAMAGES INCLUDE, BUT ARE NOT LIMITED TO, costs of REMOVAL AND REINSTALLATION OF ITEMS, Loss of GOODWILL, LOSS OF PROFITS, LOSS OF USE OR INTERRUPTION OF BUSINESS.

**WARRANTY VOID IF NOT REGISTERED**

**MAYO**  
**RAIL CAR LOADER Model 920**

**WARRANTY REGISTRATION FORM & INSPECTION REPORT**

**WARRANTY REGISTRATION (please print)**

This form must be filled out by the dealer and signed by both the dealer and the customer at the time of delivery.

|                                  |                                  |
|----------------------------------|----------------------------------|
| Customer's Name _____            | Dealer Name _____                |
| Address _____                    | Address _____                    |
| City, State/Province, Code _____ | City, State/Province, Code _____ |
| Phone Number ( ____ ) _____      | Phone Number ( ____ ) _____      |
| Contact Name _____               |                                  |
| Model _____                      |                                  |
| Serial Number _____              |                                  |
| Delivery Date _____              |                                  |

**DEALER INSPECTION REPORT**

- \_\_\_\_ Inspect Hydraulic System Components
- \_\_\_\_ Machine Lubricated
- \_\_\_\_ Conveying Belts Tensioned and Aligned
- \_\_\_\_ Hydraulic Reservoir Oil Level Checked
- \_\_\_\_ Lubricate Machine
- \_\_\_\_ Check that Discharge Conveyors Telescope and Retract Freely

**SAFETY**

- \_\_\_\_ Guards and Shields Installed and Secured
- \_\_\_\_ Review Operating and Safety Instructions
- \_\_\_\_ All Decals Installed
- \_\_\_\_ Safety Chain on Hitch

I have thoroughly instructed the buyer on the above described equipment which review included the Operator's Manual content, equipment care, adjustments, safe operation and applicable warranty policy.

Date \_\_\_\_\_ Dealer's Rep. Signature \_\_\_\_\_

The above equipment and Operator's Manual have been received by me and I have been thoroughly instructed as to care, adjustments, safe operation and applicable warranty policy.

Date \_\_\_\_\_ Owner's Signature \_\_\_\_\_

|                |        |          |
|----------------|--------|----------|
| WHITE          | YELLOW | PINK     |
| MAYO MFG., INC | DEALER | CUSTOMER |

# SERIAL NUMBER LOCATION

Always give your dealer the serial number of your Mayo Manufacturing Rail Car Loader when ordering parts or requesting service or other information.

The serial number plate is located where indicated. Please mark the number in the space provided for easy reference.



**SERIAL NUMBER LOCATION**

**Model** \_\_\_\_\_ **920** \_\_\_\_\_

**Serial Number** \_\_\_\_\_

# TABLE OF CONTENTS

| SECTION  | DESCRIPTION                         | PAGE      |
|----------|-------------------------------------|-----------|
| <b>1</b> | <b>Introduction .....</b>           | <b>1</b>  |
| <b>2</b> | <b>Safety .....</b>                 | <b>2</b>  |
| 2.1      | General Safety.....                 | 3         |
| 2.2      | Equipment Safety Guidelines .....   | 4         |
| 2.3      | Hydraulic Safety .....              | 4         |
| 2.4      | Safety Training.....                | 5         |
| 2.5      | Safety Signs .....                  | 5         |
| 2.6      | Preparation .....                   | 6         |
| 2.7      | Installation Safety .....           | 6         |
| 2.8      | Operating Safety.....               | 7         |
| 2.9      | Transport Safety .....              | 7         |
| 2.10     | Maintenance Safety .....            | 8         |
| 2.11     | Lock-Out Tag-Out Safety .....       | 8         |
| 2.12     | Storage Safety .....                | 8         |
| 2.13     | Tire Safety .....                   | 8         |
| 2.14     | Employee Sign-Off Form .....        | 9         |
| <b>3</b> | <b>Safety Sign Locations .....</b>  | <b>10</b> |
| <b>4</b> | <b>Operation.....</b>               | <b>15</b> |
| 4.1      | To the New Operator or Owner.....   | 15        |
| 4.2      | Machine Components.....             | 16        |
| 4.3      | General Operation Theory .....      | 17        |
| 4.4      | Machine Break-In .....              | 18        |
| 4.5      | Pre-Operation Checklist .....       | 18        |
| 4.6      | Controls .....                      | 19        |
| 4.7      | Operating .....                     | 24        |
| 4.8      | Storage .....                       | 33        |
| 4.9      | Transport .....                     | 35        |
| <b>5</b> | <b>Service and Maintenance.....</b> | <b>37</b> |
| 5.1      | Service.....                        | 37        |
| 5.2      | Maintenance .....                   | 48        |
| <b>6</b> | <b>Trouble Shooting .....</b>       | <b>52</b> |
| <b>7</b> | <b>Specifications .....</b>         | <b>53</b> |
| 7.1      | Mechanical .....                    | 53        |
| 7.2      | Bolt Torque.....                    | 54        |
| 7.3      | Lubrication .....                   | 55        |
| 7.4      | Hydraulic.....                      | 55        |
| <b>8</b> | <b>Index .....</b>                  | <b>56</b> |

# 1 INTRODUCTION

Congratulations on your choice of a Mayo Model 920 Rail Car Loader and welcome to Mayo's quality line of potato handling equipment. This equipment is designed and manufactured to meet the needs of a discriminating buyer in the agricultural industry for the conveying of potatoes into a rail car.

Safe, efficient and trouble free operation of your new 920 Rail Car Loader requires that you, and anyone else who will be operating or maintaining the Rail Car Loader, read, understand and practice ALL of the Safety, Operation, Maintenance and Trouble Shooting recommendations contained within this Operator's Manual.



This manual applies to Model 920 Rail Car Loader manufactured by Mayo. Certain options may be available to specifically tailor the Rail Car Loader to your operation and may not be included in this manual. Please contact the manufacturer regarding additional information about these options. Use the Table of Contents and Index as a guide to find specific information.

Keep this manual handy for frequent reference and so that it will be passed on to new operators or owners. Call your Mayo dealer if you need assistance, information or additional copies of this manual.

**MACHINE ORIENTATION** - The hitch end of the Rail Car Loader is the front. The controls are mounted on the left side.

## 2 SAFETY

### SAFETY ALERT SYMBOL

This Safety Alert symbol means  
**ATTENTION! BECOME ALERT!**  
**YOUR SAFETY IS INVOLVED!**

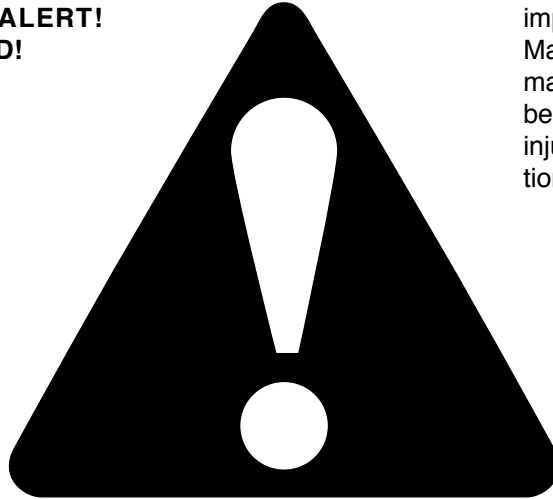

The Safety Alert symbol identifies important safety messages on your Mayo Rail Car Loader and in the manual. When you see this symbol, be alert to the possibility of personal injury or death. Follow the instructions in the safety message.

Why is SAFETY important to you?

#### 3 Big Reasons

**Accidents Disable and Kill**  
**Accidents Cost You Money**  
**Accidents Can Be Avoided**

#### SIGNAL WORDS:

Note the use of the signal words **DANGER**, **WARNING** and **CAUTION** with the safety messages. The appropriate signal word for each message has been selected using the following guide-lines:

**DANGER** - Indicates an imminently hazardous situation that, if not avoided, will result in death or serious injury. This signal word is to be limited to the most extreme situations, typically for machine components that, for functional purposes, cannot be guarded.

**WARNING** - Indicates a potentially hazardous situation that, if not avoided, could result in death or serious injury, and includes hazards that are exposed when guards are removed. It may also be used to alert against unsafe practices.

**CAUTION** - Indicates a potentially hazardous situation that, if not avoided, may result in minor or moderate injury. It may also be used to alert against unsafe practices.

If you have any questions not answered in this manual or require additional copies or the manual is damaged, please contact your dealer or Mayo, P.O. Box 497, Bus Highway 2, East Grand Forks, Minnesota, 56721. (Telephone) 218-773-1234, (FAX) 218-773-6693 or toll free at 1-800-223-5873.

# SAFETY

**YOU** are responsible for the **SAFE** operation and maintenance of your Mayo Rail Car Loader. **YOU** must ensure that you and anyone else who is going to operate, maintain or work around the Rail Car Loader be familiar with the operating and maintenance procedures and related **SAFETY** information contained in this manual. This manual will take you step-by-step through your working day and alerts you to all good safety practices while operating the Rail Car Loader.

Remember, **YOU** are the key to safety. Good safety practices not only protect you but, also the people around you. Make these practices a working part of your safety program. Be certain that **EVERYONE** operating this machine is familiar with the procedures recommended and follows safety precautions. Remember, most accidents can be prevented. Do not risk injury or death by ignoring good safety practices.

- Read and understand the Operator's Manual and all safety signs before starting engine, operating, maintaining or adjusting the Rail Car Loader.
- The most important safety device on this equipment is a **SAFE** operator. It is the operator's responsibility to read and understand **ALL** Safety and Operating instructions in the manual and to follow these. Most accidents can be avoided.
- A person who has not read and understood all operating and safety instructions is not qualified to operate this machine. An untrained operator exposes himself and bystanders to possible serious injury or death.
- Do not modify the equipment in any way. Unauthorized modification may impair the function and/or safety and could affect the life of the equipment.
- Think SAFETY! Work SAFELY!

## 2.1 GENERAL SAFETY

1. Read and understand the Operator's Manual and all safety signs before supplying power, operating, maintaining or adjusting Rail Car Loader.



2. Only trained, competent persons shall operate the Rail Car Loader. An untrained operator is not qualified to operate this machine.

3. Provide a first-aid kit for use in case of an accident. Store in a highly visible place.



4. Provide a fire extinguisher for use in case of an accident. Store in a highly visible place.

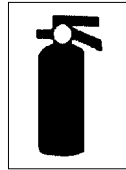

5. Install and properly secure all guards and shields before operating.

6. Wear appropriate protective gear. This list includes but is not limited to:

- Protective shoes with slip resistant soles
- Protective glasses or goggles
- Heavy gloves
- Hearing protection



7. Turn power OFF, place controls in their OFF position, relieve hydraulic pressure and wait for all moving parts to stop before servicing, adjusting, maintaining, repairing or cleaning.
8. Know the emergency medical center number for your area.
9. Review safety related items with all operators annually.



## 2.2 EQUIPMENT SAFETY GUIDELINES

1. Safety of the operator and bystanders is one of the main concerns in designing and developing a machine. However, every year many accidents occur which could have been avoided by a few seconds of thought and a more careful approach to handling equipment. You, the operator, can avoid many accidents by observing the following precautions in this section. To avoid personal injury or death, study the following precautions and insist those working with you, or for you, follow them.
2. In order to provide a better view, certain photographs or illustrations in this manual may show an assembly with a safety shield removed. However, equipment should never be operated in this condition. Keep all shields in place. If shield removal becomes necessary for repairs, replace the shield prior to use.
3. Replace any safety sign or instruction sign that is not readable or is missing. Location of such safety signs is indicated in this manual.
4. Never use alcoholic beverages or drugs which can hinder alertness or coordination while operating this equipment. Consult your doctor about operating this machine while taking prescription medications.
5. **Under no circumstances should young children be allowed to work with this equipment. Do not allow persons to operate or assemble this unit until they have read this manual and have developed a thorough understanding of the safety precautions and of how it works. Review the safety instructions with all users annually.**
6. This equipment is dangerous to children and persons unfamiliar with its operation. The operator should be a responsible, properly trained and physically able person familiar with farm machinery and trained in this equipment's operations. If the elderly are assisting with farm work, their physical limitations need to be recognized and accommodated.
7. Never exceed the limits of a piece of machinery. If its ability to do a job, or to do so safely, is in question - **DON'T TRY IT.**
8. Do not modify the equipment in any way. Unauthorized modification result in serious injury or death and may impair the function and life of the equipment.

9. In addition to the design and configuration of this implement, including Safety Signs and Safety Equipment, hazard control and accident prevention are dependent upon the awareness, concern, prudence, and proper training of personnel involved in the operation, transport, maintenance, and storage of the machine. Refer also to Safety Messages and operation instruction in each of the appropriate sections of the auxiliary equipment and machine Manuals. Pay close attention to the Safety Signs affixed to the auxiliary equipment and the machine.

## 2.3 HYDRAULIC SAFETY

1. Make sure that all the components in the hydraulic system are kept in good condition and are clean.
2. Before applying pressure to the system, make sure all components are tight, and that lines, hoses and couplings are not damaged.
3. Do not attempt any makeshift repairs to the hydraulic lines, fittings or hoses by using tapes, clamps or cements. The hydraulic system operates under extremely high pressure. Such repairs will fail suddenly and create a hazardous and unsafe condition.
4. Wear proper hand and eye protection when searching for a high pressure hydraulic leak. Use a piece of wood or cardboard as a backstop instead of hands to isolate and identify a leak.
5. If injured by a concentrated high-pressure stream of hydraulic fluid, seek medical attention immediately. Serious infection or toxic reaction can develop from hydraulic fluid piercing the skin surface.
6. Relieve pressure on hydraulic system before maintaining or working on system.

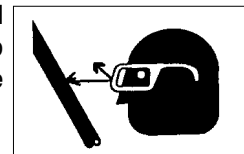

## 2.4 SAFETY TRAINING

1. Safety is a primary concern in the design and manufacture of our products. Unfortunately, our efforts to provide safe equipment can be wiped out by a single careless act of an operator or bystander.
2. In addition to the design and configuration of equipment, hazard control and accident prevention are dependent upon the awareness, concern, prudence and proper training of personnel involved in the operation, transport, maintenance and storage of this equipment.
3. It has been said, "The best safety feature is an informed, careful operator." We ask you to be that kind of an operator. It is the operator's responsibility to read and understand ALL Safety and Operating instructions in the manual and to follow these. Most accidents can be avoided.
4. **Working with unfamiliar equipment can lead to careless injuries. Read this manual, and the manual for your auxiliary equipment, before assembly or operating, to acquaint yourself with the machines. If this machine is used by any person other than yourself. It is the machine owner's responsibility to make certain that the operator, prior to operating:**
  - a. **Reads and understands the operator's manuals.**
  - b. **Is instructed in safe and proper use.**
5. Know your controls and how to stop auxiliary conveyors and any other auxiliary equipment quickly in an emergency. Read this manual and the one provided with your other equipment.
6. Train all new personnel and review instructions frequently with existing workers. Be certain only a properly trained and physically able person will operate the machinery. A person who has not read and understood all operating and safety instructions is not qualified to operate the machine. An untrained operator exposes himself and bystanders to possible serious injury or death. If the elderly are assisting with farm work, their physical limitations need to be recognized and accommodated.

## 2.5 SAFETY SIGNS

1. Keep safety signs clean and legible at all times.
2. Replace safety signs that are missing or have become illegible.
3. Replaced parts that displayed a safety sign should also display the current sign.
4. Safety signs displayed in Section 3 each have a part number in the lower right hand corner. Use this part number when ordering replacement parts.
5. Safety signs are available from your authorized Distributor or Dealer Parts Department or the factory.

### How to Install Safety Signs:

- Be sure that the installation area is clean and dry.
- Be sure temperature is above 50° F (10° C).
- Determine exact position before you remove the backing paper. (See Section 3).
- Remove the smallest portion of the split backing paper.
- Align the sign over the specified area and carefully press the small portion with the exposed sticky backing in place.
- Slowly peel back the remaining paper and carefully smooth the remaining portion of the sign in place.
- Small air pockets can be pierced with a pin and smoothed out using the piece of sign backing paper.

## 2.6 PREPARATION

1. Never operate the Rail Car Loader and auxiliary equipment until you have read and completely understand this manual, the auxiliary equipment Operator's Manual, and each of the Safety Messages found on the safety signs on the Rail Car Loader and auxiliary equipment.

2. Personal protection equipment including hard hat, safety glasses, safety shoes, and gloves are recommended during assembly, installation, operation, adjustment, maintaining, repairing, removal, or moving the implement. Do not allow long hair, loose fitting clothing or jewelry to be around equipment.



3. **PROLONGED EXPOSURE TO LOUD NOISE MAY CAUSE PERMANENT HEARING LOSS!**

Motors or equipment attached can often be noisy enough to cause permanent, partial hearing loss. We recommend that you wear hearing protection on a full-time basis if the noise in the Operator's position exceeds 80 db. Noise over 85 db on a long-term basis can cause severe hearing loss. Noise over 90 db adjacent to the Operator over a long-term basis may cause permanent, total hearing loss. **NOTE:** Hearing loss from loud noise (from tractors, chain saws, radios, and other such sources close to the ear) is cumulative over a lifetime without hope of natural recovery.

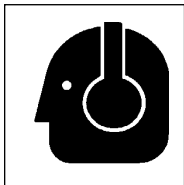

4. Clear working area of debris, trash or hidden obstacles that might be hooked or snagged, causing injury, damage or tripping.

5. Operate only in daylight or good artificial light.
6. Be sure machine is properly anchored, adjusted and in good operating condition.
7. Ensure that all safety shielding and safety signs are properly installed and in good condition.
8. Before starting, give the machine a "once over" for any loose bolts, worn parts, cracks, leaks, loose belts and make necessary repairs. Always follow maintenance instructions.

## 2.7 INSTALLATION SAFETY

1. Remove all transport devices that would hinder or prohibit the normal functioning of the machine upon start up. Serious damage to the machine and/or personal injury to the operator and bystanders may result from attempting to operate the machines while transport locking devices are still in place.
2. Position the machines on firm, level ground before operating.
3. Have at least one extra person available to assist when elevating, moving or connecting to other equipment.
4. If using Rail Car Loader as part of material handling system, anchor securely to other conveying equipment before starting.

## 2.8 OPERATING SAFETY

1. Make sure that anyone who will be operating the Rail Car Loader or working on or around the units reads and understands all the operating, maintenance and safety information in the operator's manual. Also read and follow the instructions in the manuals of other equipment in the system.
2. **Turn power OFF, place controls in their OFF position, relieve hydraulic pressure and wait for all moving parts to stop before servicing, adjusting, maintaining, repairing or cleaning.**
3. Establish a lock-out tag-out policy for the work site. Be sure all personnel are trained in and follow all procedures. Lock-out tag-out all power sources before servicing the unit or working around loading/unloading equipment.
4. Keep working area clean and free of debris to prevent slipping or tripping.
5. Stay away from overhead power lines when operating. Electrocutation can occur without direct contact.
6. Keep hands, feet, hair and clothing away from rotating and moving parts. Keep others away.
7. Install and secure all guards before starting.
8. Review safety related items annually with all personnel who will be operating, using or maintaining the Rail Car Loader.

## 2.9 TRANSPORT SAFETY

1. Make certain that you are in compliance with local, state/provincial and federal regulations regarding transporting agricultural equipment on public roadways. Mount an optional lighting bar to provide lights when travelling on a public road.
2. Make certain that all wheels and tires are in good repair and that tires are inflated to proper pressure. Do not underinflate or overinflate.
3. Make certain that all wheel bolts/lug nuts are tightened to proper torque specifications (refer to specification chart in Section 7.2).
4. Make certain that all mechanical locks are safely installed before loading or transporting.
5. Raise and secure all jack stands and outriggers.
6. Be sure that any necessary SMV (slow moving vehicle) signs, reflectors and lights required by law are in proper place and are clearly visible to oncoming and overtaking traffic.
7. Be sure that the Rail Car Loader is positively hitched to the towing vehicle. Use a proper safety chain to assure a safe hitch hook-up when transporting.
8. Adhere to local regulations regarding maximum weight, width and length.
9. Do not exceed 15 mph (25 Km/H). Reduce speed when transporting with a tractor on rough roads and surfaces.
10. Do not allow anyone to ride on the Rail Car Loader or towing vehicle during transport.
11. Always use hazard flashers on the towing vehicle when transporting.

## 2.10 MAINTENANCE SAFETY

1. Good maintenance is your responsibility. Poor maintenance is an invitation to trouble.

2. Follow good shop practices:

- Keep service area clean and dry.
- Be sure electrical outlets and tools are properly grounded.
- Use adequate light for the job at hand.



3. **Turn power OFF, place controls in their OFF position, relieve hydraulic pressure and wait for all moving parts to stop before servicing, adjusting, maintaining, repairing or cleaning.**

4. Always use personal protection devices such as eye, hand and hearing protectors, when performing any service or maintenance.

5. Where replacement parts are necessary for periodic maintenance and servicing, genuine factory replacement parts must be used to restore your equipment to original specifications. The manufacturer will not be responsible for injuries or damages caused by use of unapproved parts and/or accessories.

6. A fire extinguisher and first aid kit should be kept readily accessible while performing maintenance on this equipment.

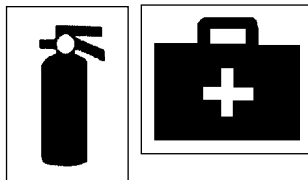

7. Periodically tighten all bolts, nuts and screws and check that all cotter pins are properly installed to ensure unit is in a safe condition.

8. When completing a maintenance or service function, make sure all safety shields and devices are installed before placing unit in service.

## 2.11 LOCK-OUT TAG-OUT SAFETY

1. Establish a formal Lock-Out Tag-Out program for your operation.

2. Train all operators and service personnel before allowing them to work around the loading system.

3. Provide tags on the machine and a sign-up sheet to record tag out details.

## 2.12 STORAGE SAFETY

1. Store the Rail Car Loader on a firm, level surface.

2. If required, make sure the unit is solidly blocked up.

3. Make certain all mechanical locks are safely and positively installed and connected before storing.

4. Store away from areas of human activity.

5. Do not permit children to play on or around the stored machine.

6. Disconnect power cord and hang on the side of the machine.

## 2.13 TIRE SAFETY

1. Inflate tires to proper pressure as specified on the side wall of each tire. Do not over-inflate or under-inflate.

2. Failure to follow proper procedures when mounting a tire on a wheel or rim can produce an explosion which may result in serious injury or death.

3. Do not attempt to mount a tire unless you have the proper equipment and experience to do the job.

4. Have a qualified tire dealer or repair service perform required tire maintenance.

## 2.14 EMPLOYEE SIGN-OFF FORM

Mayo Manufacturing, Inc. follows the general Safety Standards specified by the American Society of Agricultural Engineers (ASAE) and the Occupational Safety and Health Administration (OSHA). Anyone who will be operating and/or maintaining a Mayo built machine must read and clearly understand ALL Safety, Operating and Maintenance information presented in this manual.

Do not operate or allow anyone else to operate this equipment until such information has been reviewed. Annually review this information before the season start-up.

Make these periodic reviews of SAFETY and OPERATION a standard practice for all of your equipment. We feel that an untrained operator is unqualified to operate this machine.

A sign-off sheet is provided for your record keeping to show that all personnel who will be working with the equipment have read and understand the information in the Operator's Manual and have been instructed in the operation of the equipment.

### SIGN-OFF FORM

| DATE | EMPLOYEES SIGNATURE | EMPLOYERS SIGNATURE |
|------|---------------------|---------------------|
|      |                     |                     |
|      |                     |                     |
|      |                     |                     |
|      |                     |                     |
|      |                     |                     |
|      |                     |                     |
|      |                     |                     |
|      |                     |                     |
|      |                     |                     |
|      |                     |                     |
|      |                     |                     |
|      |                     |                     |
|      |                     |                     |
|      |                     |                     |
|      |                     |                     |
|      |                     |                     |
|      |                     |                     |
|      |                     |                     |
|      |                     |                     |
|      |                     |                     |
|      |                     |                     |
|      |                     |                     |
|      |                     |                     |
|      |                     |                     |
|      |                     |                     |

### 3 SAFETY SIGN LOCATIONS

The types of safety signs and locations on the equipment are shown in the illustrations that follow. Good safety requires that you familiarize yourself with the various Safety Signs, the type of warning and the area, or particular function related to that area, that requires your SAFETY AWARENESS.

- Think SAFETY! Work SAFELY!



**A**

**CAUTION**

- Read Operator's Manual before starting. Review safety instructions annually.
- Shut off conveyors and hydraulic pumps, unplug power cord and wait for all moving parts to stop before servicing, repairing or unplugging.
- Keep all electrical components tight, dry and in good repair.
- Keep all hydraulic components tight, dry and in good repair.
- Replace all worn or failed components immediately.
- Install and secure all guards before operating.
- Keep hands, feet, hair and clothing away from moving parts.
- Install safety locks under the boom and elevator before transporting or working underneath.
- Lower boom elevator to safety locks, center boom and install all safety locks before transporting.
- Stay away from overhead power lines and obstruction when moving (electrocution can occur without direct contact).
- Do not stand or climb on machine when operating. Keep others off.
- Have only a qualified electrician provide power to the machine(s).

**B**

**WARNING**

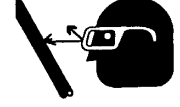
**HIGH-PRESSURE FLUID HAZARD**

To prevent serious injury or death from high-pressure fluid:

- Relieve pressure on system before repairing, adjusting or disconnecting.
- Wear proper hand and eye protections when searching for leaks. Use wood or cardboard instead of hands.
- Keep all components in good repair.

REMEMBER - If Safety Signs have been damaged, removed, become illegible or parts replaced without safety signs, new signs must be applied. New safety signs are available from your authorized dealer.

The types of safety signs and locations on the equipment are shown in the illustrations that follow. Good safety requires that you familiarize yourself with the various Safety Signs, the type of warning and the area, or particular function related to that area, that requires your SAFETY AWARENESS.

- Think SAFETY! Work SAFELY!



**C**

|  |  |
|--|--|
| <b>WARNING</b>   |  |
|  |  |
| <b>MOVING PART HAZARD</b>  |  |
| To prevent serious injury or death from falling:   |  |
| <ol style="list-style-type: none"> <li>1. Do not stand or climb on machine when operating. Keep others off.</li> <li>2. Keep hands away from moving parts.</li> <li>3. Wear tight clothing and safety gear.</li> </ol> |  |

**D**

|   |  |
|---|--|
| <b>WARNING</b>  |  |
|   |  |
| <b>ROTATING PART HAZARD</b>   |  |
| <b>KEEP AWAY</b>  |  |
| To prevent serious injury or death from rotating parts:   |  |
| <ul style="list-style-type: none"> <li>• Keep all guards and shields in place.</li> <li>• Keep hands, feet, hair and clothing away from moving parts.</li> <li>• Keep others away.</li> </ul> |  |

**E**

|  |  |
|--|--|
| <b>DANGER</b>  |  |
|  |  |
| <b>MISSING GUARD HAZARD</b>  |  |
| To prevent serious injury or death:  |  |
| <ul style="list-style-type: none"> <li>• Install and secure guard before operating.</li> </ul> |  |

REMEMBER - If Safety Signs have been damaged, removed, become illegible or parts replaced without safety signs, new signs must be applied. New safety signs are available from your authorized dealer.



The types of safety signs and locations on the equipment are shown in the illustrations that follow. Good safety requires that you familiarize yourself with the various Safety Signs, the type of warning and the area, or particular function related to that area, that requires your SAFETY AWARENESS.

- Think SAFETY! Work SAFELY!



**F**

**WARNING**

**PINCH POINT HAZARD**  
To prevent serious injury or death:

- Keep away from frame when moving components.
- Keep others away.

**H**

**WARNING**

To prevent serious injury or death:

- Install mechanical lock between elevator and boom frames before transporting.

**G**

**WARNING**

To prevent serious injury or death:

- Install mechanical lock under boom before transporting or working beneath boom.

**J**

**DANGER**

**ELECTROCUTION HAZARD**

- Have a licensed electrician provide power.
- Keep electrical components dry and in good repair.

Failure to follow these instructions can result in serious injury or death.

REMEMBER - If Safety Signs have been damaged, removed, become illegible or parts replaced without safety signs, new signs must be applied. New safety signs are available from your authorized dealer.

The types of safety signs and locations on the equipment are shown in the illustrations that follow. Good safety requires that you familiarize yourself with the various Safety Signs, the type of warning and the area, or particular function related to that area, that requires your SAFETY AWARENESS.

- Think SAFETY! Work SAFELY!



K

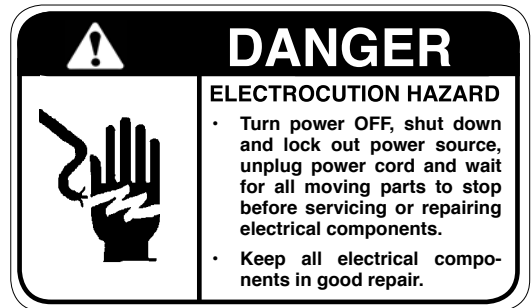

L

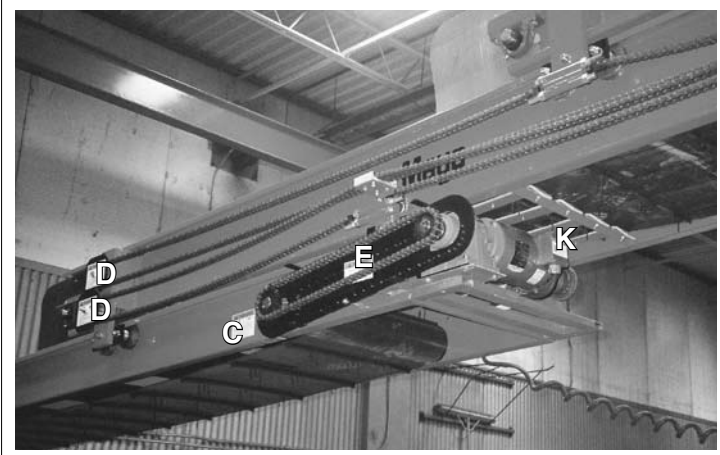

M



REMEMBER - If Safety Signs have been damaged, removed, become illegible or parts replaced without safety signs, new signs must be applied. New safety signs are available from your authorized dealer.

The types of safety signs and locations on the equipment are shown in the illustrations that follow. Good safety requires that you familiarize yourself with the various Safety Signs, the type of warning and the area, or particular function related to that area, that requires your SAFETY AWARENESS.

- Think SAFETY! Work SAFELY!

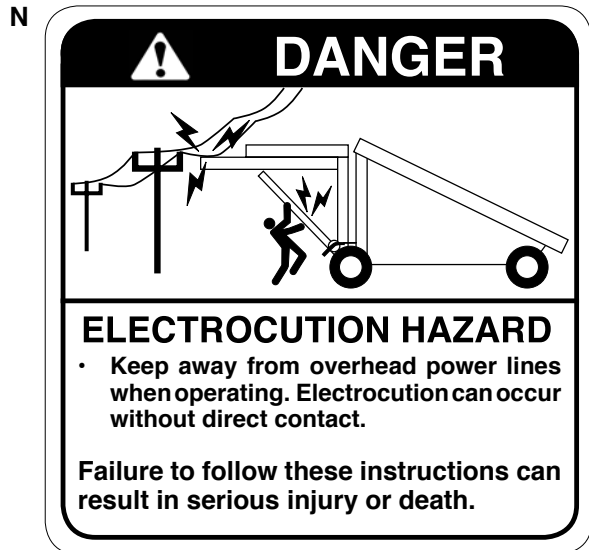

REMEMBER - If Safety Signs have been damaged, removed, become illegible or parts replaced without safety signs, new signs must be applied. New safety signs are available from your authorized dealer.

## 4 OPERATION



### OPERATING SAFETY

- Make sure that anyone who will be operating the Rail Car Loader or working on or around the units reads and understands all the operating, maintenance and safety information in the operator's manual. Also read and follow the instructions in the manuals of other equipment in the system.
- **Turn power OFF, place controls in their OFF position, relieve hydraulic pressure and wait for all moving parts to stop before servicing, adjusting, maintaining, repairing or cleaning.**
- Establish a lock-out tag-out policy for the work site. Be sure all personnel are trained in and follow all procedures. Lock-out tag-out all power sources before servicing the unit or working around loading/unloading equipment.
- Keep working area clean and free of debris to prevent slipping or tripping.
- Stay away from overhead power lines when operating. Electrocutation can occur without direct contact.
- Keep hands, feet, hair and clothing away from rotating and moving parts. Keep others away.
- Install and secure all guards before starting.
- Review safety related items annually with all personnel who will operating, using or maintaining the Rail Car Loader.

### 4.1 TO THE NEW OPERATOR OR OWNER

The Mayo Manufacturing Rail Car Loader is designed to convey product from a transporting vehicle or storage facility into a rail car. Be familiar with the machine before starting.

**It is the responsibility of the owner or operator to read this manual and to train all other operators before they start working with the machine. In addition to the design and configuration of equipment, hazard control and accident prevention are dependent upon the awareness, concern, and prudence of personnel involved in the operation, transport, maintenance and storage of equipment or in the use of facilities.**

**Follow all safety instructions exactly. Safety is everyone's business. By following recommended procedures, a safe working environment is provided for the operator, bystanders and the area around the worksite. Untrained operators are not qualified to operate the machine.**

Many features incorporated into this machine are the result of suggestions made by customers like you. Read this manual carefully to learn how to operate the machine safely and how to set it to provide maximum efficiency. By following the operating instructions in conjunction with a good maintenance program, your Rail Car Loader will provide many years of trouble-free service.

## 4.2 MACHINE COMPONENTS

The Mayo Manufacturing Rail Car Loader is designed to convey potatoes from transport vehicle or storage facility into a rail car for transporting to another location. The three stage boom can swing through an arc of 180° to allow it to place potatoes on either end of the rail car. Stands positioned at each rear corner support the frame when the boom is extended at right angles for loading.

The master control panel is mounted on the left side of the frame. A hydraulic valve on the left front corner of the frame controls the height of the intake hopper. All other hydraulic controls are mounted on the rear frame next to the operator's platform. A remote control can also be used to operate the loader.

Electric motors power each conveyor. Hydraulic cylinders steer the machine and raise/lower the hopper and boom. Hydraulic motors move the machine and swing the boom. The hydraulic power components (electric motor, hydraulic pump, reservoir and filter) are located on the right side of the frame.



Fig. 1 MACHINE COMPONENTS

### 4.3 GENERAL OPERATION THEORY

The Rail Car Loader is used to convey potatoes from a transport vehicle or storage facility into a rail car. A swinging three stage telescoping boom extends out to place potatoes into the car. A hydraulic motor provides power to the rear wheels when the machine is manoeuvred into position.

Outrigger jacks are mounted on the back of the frame to provide stability when the boom is extended at right angles to the frame. Electric power must be provided to the motors on each conveyor and to drive the hydraulic pump. An optional remote control is available to operate the machine.



Fig. 2 POSITIONED (TYPICAL)

## 4.4 MACHINE BREAK-IN

Although there are no operational restrictions on the Rail Car Loader when used for the first time, it is recommended that the following mechanical items be checked:

A. Read Rail Car Loader and auxiliary equipment manuals before starting.

**B. After operating for 1/2 hour:**

1. Re-torque all other fasteners and hardware.
2. Check that all hydraulic fittings are tight and hoses are routed out of the way or protected.
3. Check that all electrical connections are tight and cords are routed out of the way or protected.
4. Check the alignment and tension of the conveying belts. Realign or tighten as required.
5. Check oil level in the hydraulic reservoir and the elevator gearbox. Top up as required.
6. Lubricate all grease fittings.

**C. After 2, 5 and 10 hours of operation:**

1. Re-torque all fasteners and hardware.
2. Check that all hydraulic fittings are tight and hoses are routed out of the way or protected.
3. Check that all electrical connections are tight and cords are routed out of the way or protected.
4. Check the alignment and tension of the conveying belts. Realign or tighten as required.
5. Check oil level in the hydraulic reservoir. Top up as required.
5. Then go to the regular servicing and maintenance schedule as defined in the Maintenance Section.

## 4.5 PRE-OPERATION CHECKLIST

Safe and efficient operation of your new Rail Car Loader requires that each operator reads and follows all safety precautions and operating procedures contained in this section. Performing the following pre-operation checklist is important for personal safety as well as for continued mechanical soundness and longevity of your new Mayo Rail Car Loader. The checklist should be performed before operating the machine and prior to each operation thereafter.

1. Lubricate the machine according to the schedule prescribed in the "Maintenance Section".
2. Insure that proper protective gear is in good repair and available for use by each operator. Make certain that each operator uses the protective gear. Protective gear includes but, is not limited to:

- Leather gloves
- Safety glasses or face shield
- Full length protective clothing
- Steel toed boots with slip resistant soles.



3. Insure that all safety guards and shields are in good repair and securely in place.
4. Check that the conveyor belts are properly tensioned and aligned. Adjust if required.
5. Check that all bearings turn freely. Replace any that are rough or singed.
6. Check for and remove all entangled material.
7. Make sure that all hydraulic controls are in the OFF position before starting.
8. Check that all hydraulic fittings are tight and hoses are routed out of the way or protected.
9. Check that all electrical connections are tight and cords are routed out of the way or protected.
10. Be sure the working area is clean, uncluttered and dry to prevent tripping or slipping.

## 4.6 CONTROLS

Before starting to work, all operators should familiarize themselves with the location and function of the controls. Some machines may vary slightly due to custom features but they are similar and all controls are labelled.

### 1. Master Control Panel:

This panel controls the power to the loader.

#### a. Emergency Stop:

This red button switch controls the electrical power to the machine. Depress to turn power off. Rotate 90° to release the button and it will pop out and power will be restored. Both emergency stop buttons and the one on the remote (if used) must be out before power will go on.

#### b. Remote:

This two-position rotary switch selects the operating mode for the loader. Turn fully clockwise to select controlling the machine with the remote and counterclockwise to disconnect from the remote. The valve bank at the center of the frame is now used to operate the machine.

#### c. Hydraulic Pump:

These two push buttons control the power to the hydraulic pump. Depress the top green button to turn the pump on. Depress the bottom red button to turn the pump off.

#### d. Conveyors:

These two push buttons control the power to the conveyors. Depress the top green button to turn the conveyors on. Depress the bottom red button to turn them off.



Fig. 3 MASTER CONTROL PANEL



2. **Hopper Height Control:**

This three-position spring-loaded-to-center-neutral hydraulic lever controls and sets the height of the hopper or elevator. Move and hold the lever up to raise the hopper or elevator. Move and hold the lever down to lower the hopper or elevator. Release the lever and the hopper or elevator will stop moving and remain where it is.

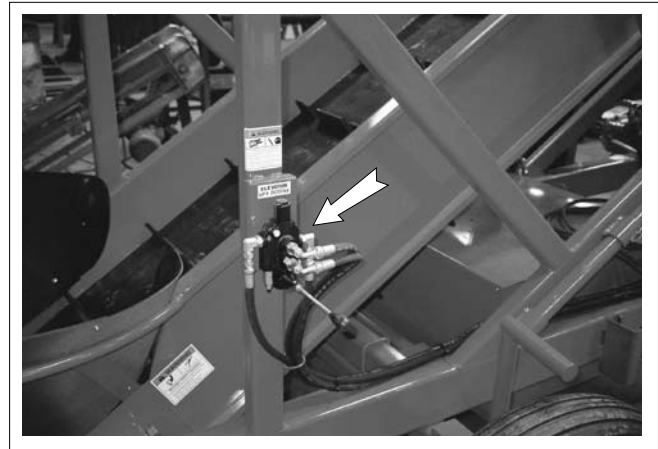

Fig. 4 HOPPER HEIGHT CONTROL

2. **Master Valve Bank:**

This six-segment hydraulic valve bank controls the remaining hydraulic functions on the machine.

a. **In/Out Speed Adjusting Knob:**

This knob controls and sets the speed at which the boom moves in and out. Turn the knob in clockwise to decrease the speed and out (counterclockwise) to increase speed.

b. **Boom In/Out:**

This three-position spring-loaded-to-neutral-center hydraulic lever controls the telescoping function of the boom. Move the lever up and hold to retract the boom. Move the lever down and hold to extend the boom. Release the lever and the boom will stop moving in and out.

c. **Boom Up/Down:**

This three-position spring-loaded-to-neutral-center hydraulic lever controls the height of the boom. Move the lever up and hold to raise the boom. Move the lever down and hold to lower the boom. Release the lever and the boom will stop moving up and down.

d. **Boom Right/Left:**

This three-position spring-loaded-to-neutral-center hydraulic lever controls the boom swing angle/position. Move the lever up and hold to swing the boom to the right. Move the lever down and hold to swing to the left. Release the lever and the boom will stop its swing motion.

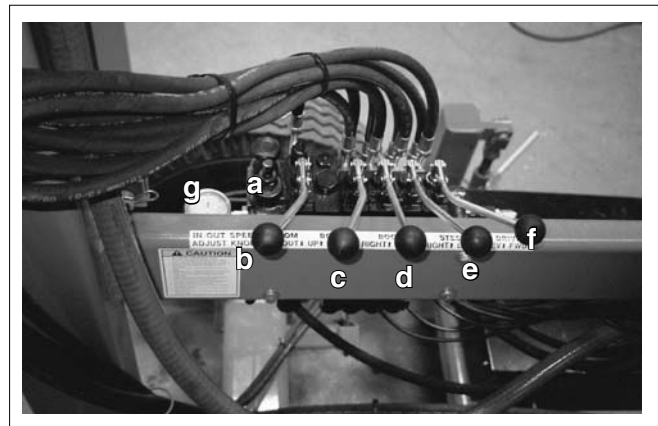

Fig. 5 MASTER VALVE BANK

e. **Steer Right/Left:**

This three-position spring-loaded-to-neutral-center hydraulic lever controls the machine steering. Move the lever up and hold to turn to the right. Move the lever down and hold to turn to the left. Release the lever and the front wheels will remain at their current angle.

f. **Machine Drive:**

This three-position spring-loaded-to-neutral-center hydraulic lever controls the power to the machine tractive drive. Move the lever up and hold to move in the reverse direction. Move the lever down and hold to move forward. Release the lever and the machine will stop moving.

g. **Pressure Gauge:**

This gauge displays the pressure in the hydraulic system. The system relief valve is set to 2000 psi from the factory.

4. **Flow Controls:**

This needle valve controls the boom raise speed. Turn the valve in to decrease the boom raise speed and out to increase it.

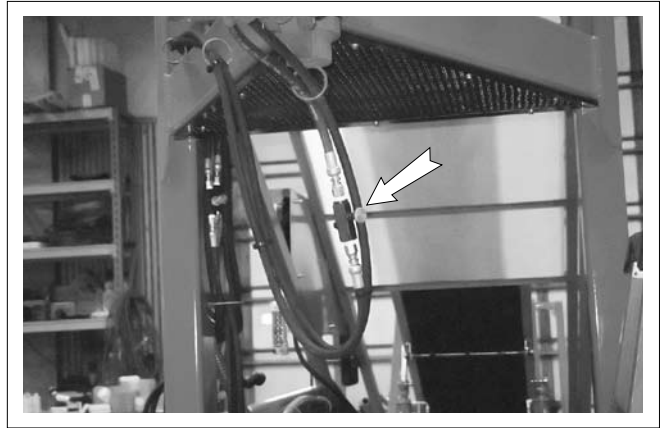

Fig. 6 BOOM RAISE SPEED

5. **Emergency Stop - Operator's Station:**

This red button switch controls the electrical power to the machine. Depress to turn the power off. Rotate 90° to release the button and it will pop out restoring power. Both emergency stop buttons and the one on the remote (if so equipped) must be out before power will come on.



Fig. 7 EMERGENCY STOP - OPERATOR'S STATION

6. **Tractive Drive Engage/Disengage:**

This handle controls the position of the internal gear that engages or disengages the gearbox. Move the handle toward the tire to engage the drive and away from the tire to disengage. Always install the anchor pin and retainer through the base to lock the handle in position.

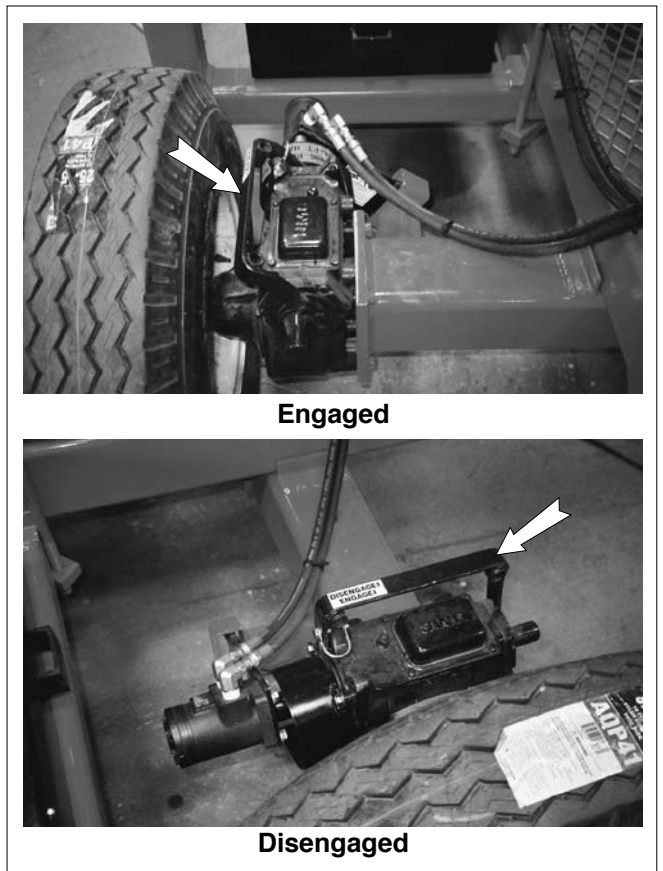

Fig. 7 TRACTIVE DRIVE ENGAGE/DISENGAGE

## 7. Remote Control:

This hand-held controller can be used to operate the loader. However the "Remote" switch on the master control panel must be turned to the "ON" position.

### a. Emergency Stop:

This red button switch controls the electrical power to the machine. Depress to turn the power off. Rotate 90° to release the button and it will pop out restoring power. Both emergency stop buttons and the one on the remote must be out before power will come on.

### b. Master Power Switch:

This three-position spring-loaded-to-run position switch controls the power to the machine. Turn the switch fully clockwise to turn the power on. Release the switch and the spring will return it to its middle "RUN" position. Turn fully counterclockwise to turn the power off.

### c. Status Lights:

These lights are lit according to the internal switch settings. Review the information in the remote manual for details.

### d. Hydraulic Pump On/Off:

This two-position latching switch controls the power to the hydraulic pump. Depress once to turn the pump on and again to turn it off.

### e. Conveyors On/Off:

This two-position latching switch controls the power to the conveyors. Depress once to turn the conveyors on and again to turn them off.

### f. Boom Height Position - Up:

This spring-loaded switch controls the boom height cylinder. Depress and hold the switch to raise the boom. Release the switch and the boom will stop moving up.

### g. Boom Height Position - Down:

This spring-loaded switch controls the boom height cylinder. Depress and hold the switch to lower the boom. Release the switch and the boom will stop moving down.

### h. Boom In:

This spring-loaded switch controls the boom telescoping function. Depress and hold the switch to telescope the boom in. Release the switch and the boom will stop telescoping.

### j. Boom Out:

This spring-loaded switch controls the boom telescoping function. Depress and hold the switch to telescope the boom out. Release the switch and the boom will stop telescoping.



Fig. 9 REMOTE CONTROL

### k. Boom Left:

This spring-loaded switch controls the boom swinging function. Depress and hold the switch to swing the boom left. Release the switch and the boom will stop.

### l. Boom Right:

This spring-loaded switch controls the boom swinging function. Depress and hold the switch to swing the boom right. Release the switch and the boom will stop.

### m. Wheel Drive - Reverse:

This spring-loaded switch provides power for the tractive drive on the rear wheels. Depress and hold the switch to move the machine in reverse. Release it and the machine will stop moving.

### n. Wheel Drive - Forward:

This spring-loaded switch provides power for the tractive drive on the rear wheels. Depress and hold the switch to move the machine forward. Release it and the machine will stop moving.

### o. Steering - Left:

This spring-loaded switch controls the steering action of the front wheels. Depress momentarily to turn the front wheels to the left. Repeat to turn them further to the left. Release the switch and the wheels will remain at their current angle.

### p. Steering - Right:

This spring-loaded switch controls the steering action of the front wheels. Depress momentarily to turn the front wheels to the right. Repeat to turn them further to the right. Release the switch and the wheels will remain at their current angle.

**8. Manual Steering:**

The loader is designed with a system that allows for steering the machine when a power source is not available. Remove the steering handle from its stowed position and slide over the steering post. Turn as required to steer the front wheels. Replace and secure handle when machine steering requirements have been completed.

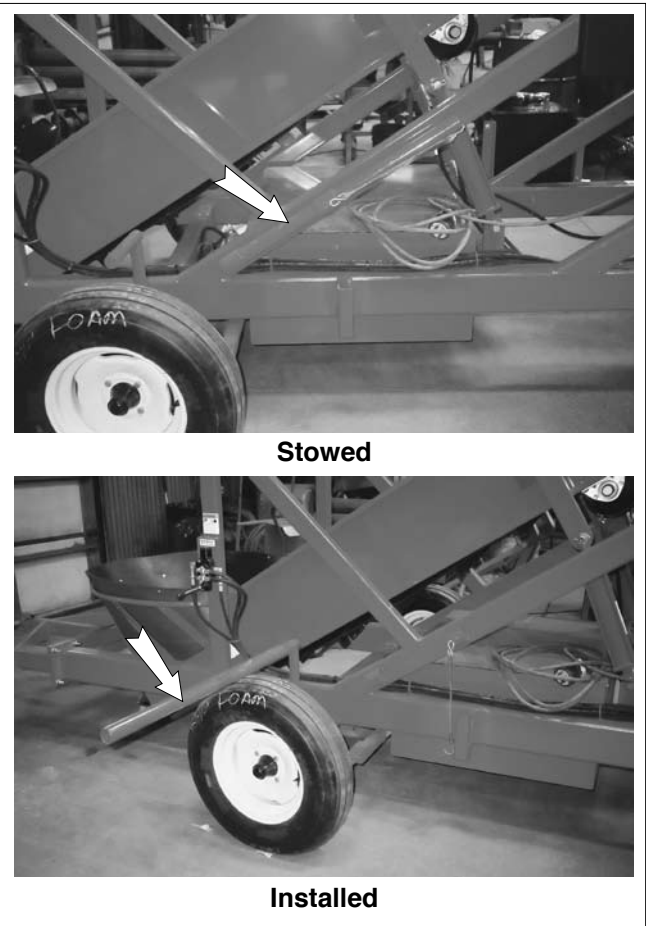

**Fig. 10 MANUAL STEERING**

## 4.7 OPERATING



### OPERATING SAFETY

- Make sure that anyone who will be operating the Rail Car Loader or working on or around the units reads and understands all the operating, maintenance and safety information in the operator's manual. Also read and follow the instructions in the manuals of other equipment in the system.
- **Turn power OFF, place controls in their OFF position, relieve hydraulic pressure and wait for all moving parts to stop before servicing, adjusting, maintaining, repairing or cleaning.**
- Establish a lock-out tag-out policy for the work site. Be sure all personnel are trained in and follow all procedures. Lock-out tag-out all power sources before servicing the unit or working around loading/unloading equipment.
- Keep working area clean and free of debris to prevent slipping or tripping.
- Stay away from overhead power lines when operating. Electrocutation can occur without direct contact.
- Keep hands, feet, hair and clothing away from rotating and moving parts. Keep others away.
- Install and secure all guards before starting.
- Review safety related items annually with all personnel who will operating, using or maintaining the Rail Car Loader.



**Fig. 11 POSITIONING**

Follow this procedure when using the Rail Car Loader:

1. Review and follow the pre-operation checklist (See Section 4.5).
2. Review the location and function of all controls (See Section 4.6).
3. Position the machine at the next to the rail car with sufficient space to allow trucks to bring potatoes to the machine or for conveyors to move potatoes out of the storage facility.

4. **Prepare the Rail Car Loader:**

- a. Move the handles toward the wheel to engage the drive wheels.

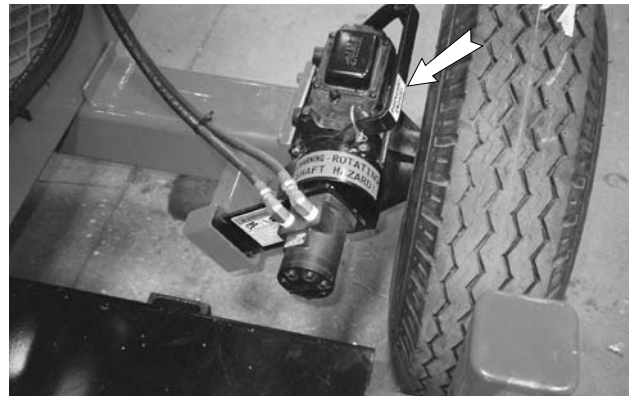

**Drive Handle**

- b. Remove the swing lock pin.



**Swing Lock**

- c. Remove the boom support transport poles.

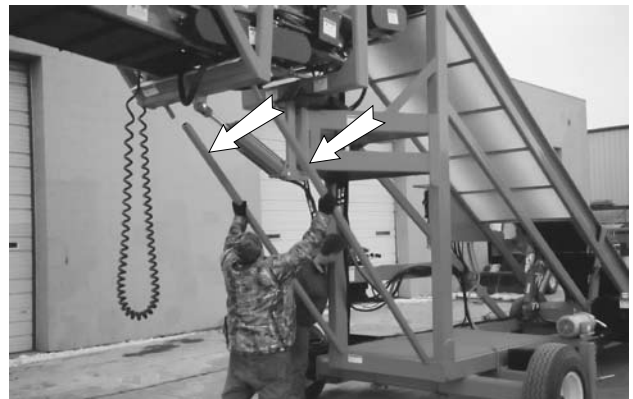

**Boom Supports**

- d. Provide power to the machine.



**Power Cord**

**Fig. 12 PREPARATION**

5. **Positioning the Rail Car Loader:**

- a. Retract boom to its shortest length.
- b. Back the loader into the rail car and carefully swing the boom into the end where the loading will start.
- c. Continue backing until the wheels contact the side of the rail care.
- d. Lower both jacks until the rear tires almost clear the ground.
- e. Place chocks on both sides of the rear tires to prevent machine movement.
- f. Attach or connect the conveyors to the front (hopper end) frame that will load potatoes into the hopper.



**Swinging**



**Chocks**

**Fig. 13 POSITIONING LOADER (Typical)**

6. **Starting the Rail Car Loader:**

- a. Clear the area of bystanders. Know where everyone is before starting.
- b. Place all controls in the OFF position.
- c. Select whether the machine will be operated by the remote control or valve bank and set the rotary switch on the master control panel.
- d. Check that all "Emergency Stop" switches are released and out.
- e. Start loader at the master control panel or with the remote.



**Master Control Panel / Frame**



**Remote Control**

**Fig. 14 EMERGENCY STOP**

7. **Stopping Machine:**

- a. Stop loading potatoes into hopper.
- b. Wait until the potatoes have moved off the boom and into the rail car.
- c. Turn the conveyors OFF.
- d. Turn pump OFF.



**Fig. 15 EMPTY MACHINE**

8. **Emergency Stop:**

If an emergency occurs, depress one of the "Emergency Stop" switches to stop the machine. Correct the condition before resuming work. Make sure all "Emergency Stop" switches are released before restarting machine.

9. **Leveling:**

The Rail Car Loader is designed with a mechanical jacks on the rear corners of the machine to stabilize the machine when the boom is extended. These jacks can also be used to level the machine during operation.

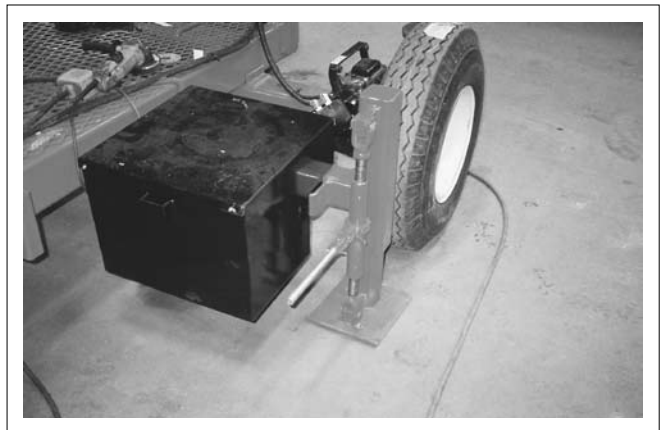

**Fig. 16 WHEEL JACKS**



10. **Boom Position:**

The boom position can be raised and lowered to accommodate the height of any rail car and height of the potatoes in the car.



**Fig. 17 BOOM HEIGHT**

**11. Swing Position:**

The boom position can swing to the left and right as required to fill each end and the center of the rail car as required. Use the swing function in conjunction with the forward and rearward motion of the frame to get into and out of the ends of the rail car.



**Right**



**Center**



**Left**

**Fig. 18 SWING POSITION**

12. **Boom Telescoping:**

The boom can telescope up to 30 feet if required to fill each end of the rail car. Telescope the boom as required for your application.

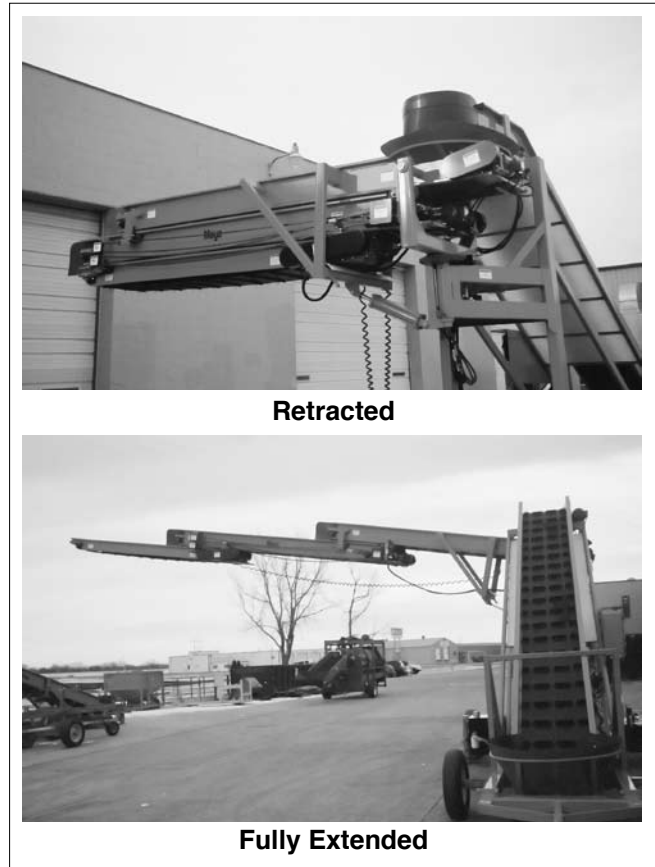

**Fig. 19 TELESCOPING**

13. **Chocks (a):**

Always place chocks in front of and behind the rear wheels when the machine is positioned for loading the rail car. Chocks will prevent any unplanned movement of the machine.

14. **Jack Stands (b):**

Jack stands are located at the rear corners of the frame. Extend both stands until the tires are almost clear of the ground to provide lateral stability during the loading cycle.

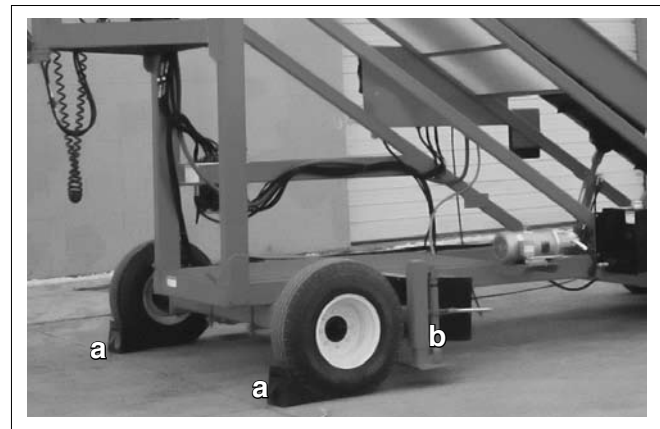

**Fig. 20 CHOCKS / JACK STANDS**

**15. Transporting:**

Always place the loader on a truck to move from location to location. Install boom frame locks to stabilize boom during transport.

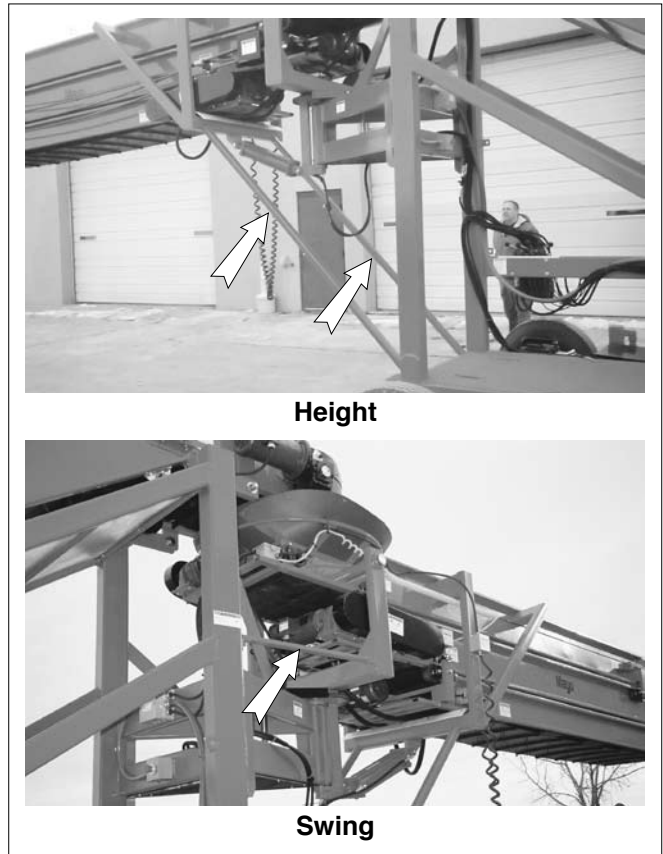

**Fig. 21 BOOM LOCKS**

**16. Towing:**

When towing the machine from location to location, always disengage the tractive drive gearbox to prevent skidding wheels.

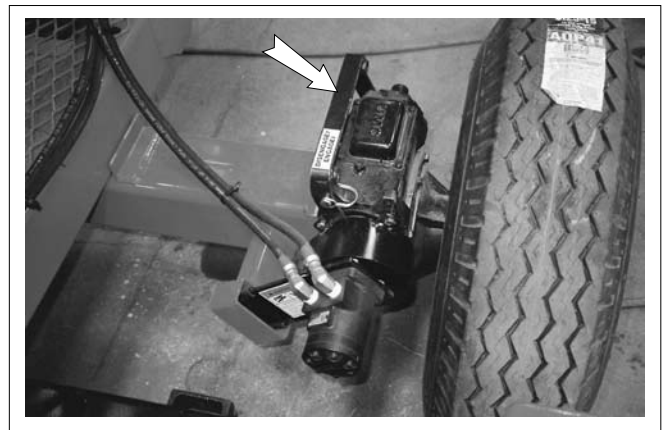

**Fig. 22 DISENGAGED (Typical)**

## 17. Operating Hints:

- a. Be sure that all workers and operators are supplied with and use the required safety gear.
- b. Keep the working area clean and as dry as possible to prevent slipping and tripping.
- c. Train all operators before starting. An untrained operator is not qualified to operate this machine and can expose himself and others to needless hazards.
- d. Always set the end of the boom and the height of the hopper to minimize the drop height as the potatoes move through the machine.
- e. Place chocks in front of and behind the rear wheels to prevent unintended movement of the machine
- f. Always lower both jack stands to the ground to provide machine stability before starting to work.



**Fig. 23 CHOCKS**

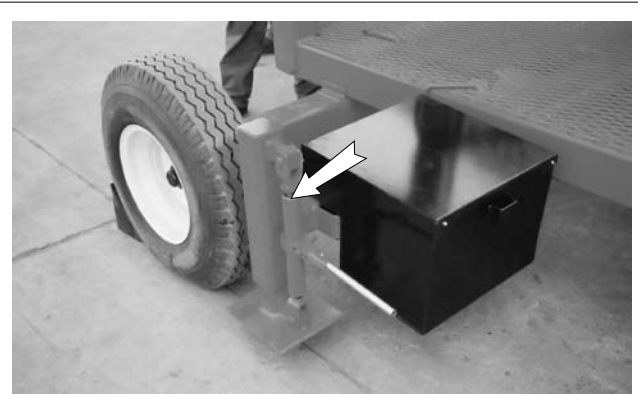

**Left**

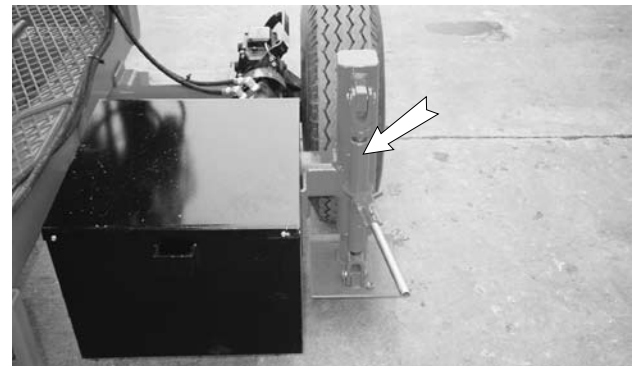

**Right**

**Fig. 24 JACK STANDS**

- g. The remote can be used to control the machine if desired. Review the controls section to be familiar with the function of each switch before starting.



**Fig. 25 REMOTE CONTROL**

## 4.8 STORAGE



### STORAGE SAFETY

- Store the Rail Car Loader on a firm, level surface.
- If required, make sure the unit is solidly blocked up.
- Make certain all mechanical locks are safely and positively installed and connected before storing.
- Store away from areas of human activity.
- Do not permit children to play on or around the stored machine.
- Disconnect power cord and hang on the side of the machine.

#### 4.8.1 PLACING IN STORAGE

At the end of the season, the machine should be thoroughly inspected and prepared for storage. Repair or replace any worn or damaged components to prevent any unnecessary down time at the beginning of the next season. Follow this procedure:

1. Install the boom height and swing lock brackets.
9. Select a storage area that is dry, level and free of debris.
3. Move the machine to storage area.
4. Turn machine power off and unplug power cord. Hang cord on frame.
2. Check all rotating parts for entangled material. Remove.
3. Thoroughly wash the machine using a pressure washer to remove all dirt, mud, debris or residue.
4. Make sure all the water drains out of all areas of the machine.
5. Lubricate all grease fittings. Make sure all grease cavities have been filled with grease to remove any water residue from the washing.
6. Inspect all the hydraulic components. Tighten any loose fittings. Replace any hose that is badly cut, nicked or abraded. Replace any damaged components.
7. Inspect all the electrical components. Tie up all loose wires. Replace any frayed wires or connections.
8. Inspect the conveyors. Check the condition of the rollers. Replace any if badly worn. Check the alignment of the conveyors. Align if required. Properly tension the conveyor belts.

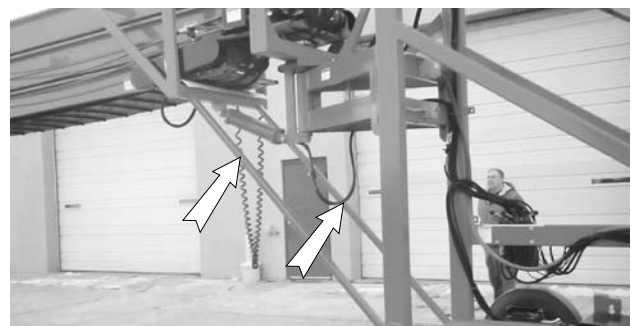

Height

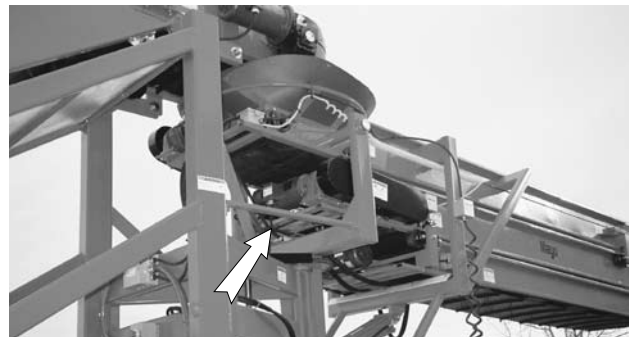

Swing

Fig. 26 BOOM LOCKS



Fig. 27 STORED (Typical)

9. Touch up all paint nicks and scratches to prevent rusting.

## **4.8.2 REMOVING FROM STORAGE**

When preparing to use the machine at the start of the season, follow this procedure:

1. Remove the tarpaulin if covered.
2. Move to the working area if appropriate.
3. Check:
  - a. Hydraulic system and components.
  - b. Electrical system and components.
  - b. All drive systems.
  - c. All hardware. Tighten as required.
4. Replace any defective components.
5. Go through the pre-operation checklist (Section 4.5) before starting.

## 4.9 TRANSPORTING / MOVING



### TRANSPORT SAFETY

- Make certain that you are in compliance with local, state/provincial and federal regulations regarding transporting agricultural equipment on public roadways. Mount an optional lighting bar to provide lights when travelling on a public road.
- Make certain that all wheels and tires are in good repair and that tires are inflated to proper pressure. Do not underinflate or overinflate.
- Make certain that all wheel bolts/lug nuts are tightened to proper torque specifications (refer to specification chart in Section 7.2).
- Make certain that all mechanical locks are safely installed before loading or transporting.
- Raise and secure all jack stands and outriggers.
- Always use hazard flashers on the towing vehicle when transporting.
- Be sure that any necessary SMV (slow moving vehicle) signs, reflectors and lights required by law are in proper place and are clearly visible to oncoming and overtaking traffic.
- Be sure that the Rail Car Loader is positively hitched to the towing vehicle. Use a proper safety chain to assure a safe hitch hook-up when transporting.
- Adhere to local regulations regarding maximum weight, width and length.
- Do not exceed 15 mph (25 Km/H). Reduce speed when transporting with a tractor on rough roads and surfaces.
- Do not allow anyone to ride on the Rail Car Loader or towing vehicle during transport.

Mayo Rail Car Loaders are designed to be easily and conveniently moved from location to location. Transporting is used to describe when the machine is being moved on a truck. Moving is when a tractor is used to move the machine around a yard or a short distance.

When transporting, follow this procedure:

1. Disconnect and move all auxiliary equipment away from the loader.
2. Raise jack stand.
3. Move machine away from rail car.

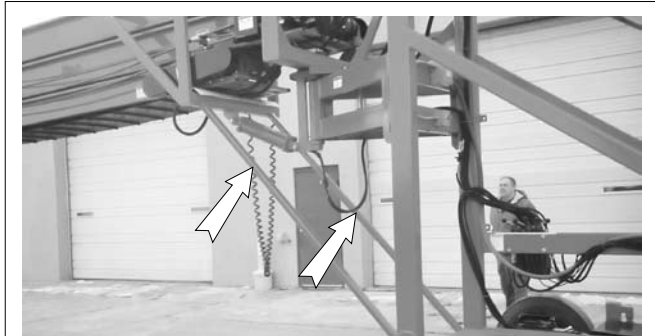

**Fig. 28 HITCH**



4. Install the transport locks:

a. Boom height lock.



**Height**

b. Boom swing lock.

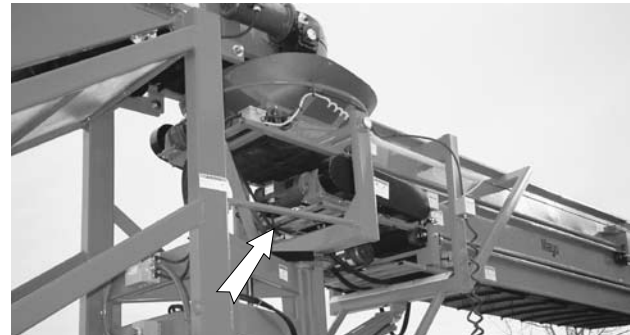

**Swing**

**Fig. 29 BOOM LOCKS**

5. Disengage traction drive handle.

6. Unplug and stow power cord.

7. Hook up to tow unit (use a retainer through hitch) and attach safety chain if moving short distance.

8. Be sure all bystanders are clear of the machine.

9. Load machine onto truck if transporting.

10. Make sure all the lights and reflectors that are required by the local highway and transport authorities are in place, are clean and can be seen clearly by all overtaking and oncoming traffic.

11. Keep to the right and yield the right-of-way to allow faster traffic to pass. Drive on the road shoulder, if permitted by law.

12. Do not exceed a safe travel speed. Slow down for rough terrain and corners.

13. Do not allow riders on the machine.

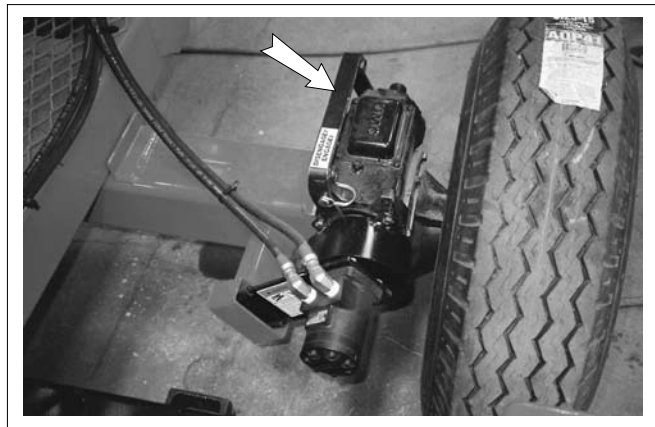

**Fig. 30 DISENGAGED (Typical)**

## 5 SERVICE AND MAINTENANCE



### MAINTENANCE SAFETY

- Good maintenance is your responsibility. Poor maintenance is an invitation to trouble.
- Follow good shop practices:
  - Keep service area clean and dry.
  - Be sure electrical outlets and tools are properly grounded.
  - Use adequate light for the job at hand.
- **Turn power OFF, place controls in their OFF position, relieve hydraulic pressure and wait for all moving parts to stop before servicing, adjusting, maintaining, repairing or cleaning.**
- Always use personal protection devices such as eye, hand and hearing protectors, when performing any service or maintenance.
- Where replacement parts are necessary for periodic maintenance and servicing, genuine factory replacement parts must be used to restore your equipment to original specifications. The manufacturer will not be responsible for injuries or damages caused by use of unapproved parts and/or accessories.
- A fire extinguisher and first aid kit should be kept readily accessible while performing maintenance on this equipment.
- Periodically tighten all bolts, nuts and screws and check that all cotter pins are properly installed to ensure unit is in a safe condition.
- When completing a maintenance or service function, make sure all safety shields and devices are installed before placing unit in service.

## 5.1 SERVICE

### 5.1.1 FLUIDS AND LUBRICANTS

1. **Grease**  
Use an SAE multi-purpose high temperature grease with extreme pressure (EP) performance meeting or exceeding the NLGI #2 rating for all requirements.
2. **Hydraulic Oil:**  
Use an Armory 32 type oil or any equivalent hydraulic oil.  
Reservoir: 20 US gal.

### 5.1.2 GREASING

Refer to Section 5.1.1 for recommended grease. Use the Maintenance Checklist provided to keep a record of all scheduled maintenance.

1. Use only a hand-held grease gun for all greasing. Air powered greasing systems can damage the seals on bearings and lead to early bearing failure.
2. Wipe grease fitting with a clean cloth before greasing to avoid injecting dirt and grit.
3. Replace and repair broken fittings immediately.
4. If a fitting will not take grease, remove and clean thoroughly. Also clean lubricant passageway. Replace fitting if necessary.
5. **Storing Lubricants:**  
Your machine can operate at top efficiency only if clean lubricants are used. Use clean containers to handle all lubricants. Store them in an area protected from dust, moisture and other contaminants.

### 5.1.3 SERVICING INTERVALS

#### 10 Hours or Daily

The period recommended is based on normal operating conditions. Severe or unusual conditions may require more frequent servicing.

1. Check machine condition:
  - a. All fasteners tight.
  - b. All hydraulic and electrical components in good condition.
  - c. Conveyors in good condition.

#### 50 Hours or Weekly

The period recommended is based on normal operating conditions. Severe or unusual conditions may require more frequent servicing.

1. Grease the conveyor roller bearings with 1 shot of grease.
  - a. **Elevator:**
    - Idler shaft.
    - Dogleg shaft.
    - Drive shaft.

#### IMPORTANT

Only sealed bearings are used on the conveyor bearings. Sealed bearings should never be greased more often than weekly or every 50 hours. Do not over grease. Do not give bearing more than 1 shot of grease each time it is greased. Once the bearing seal is broken, the bearing must be greased each day or the bearing will fail.



Fig. 31 MACHINE

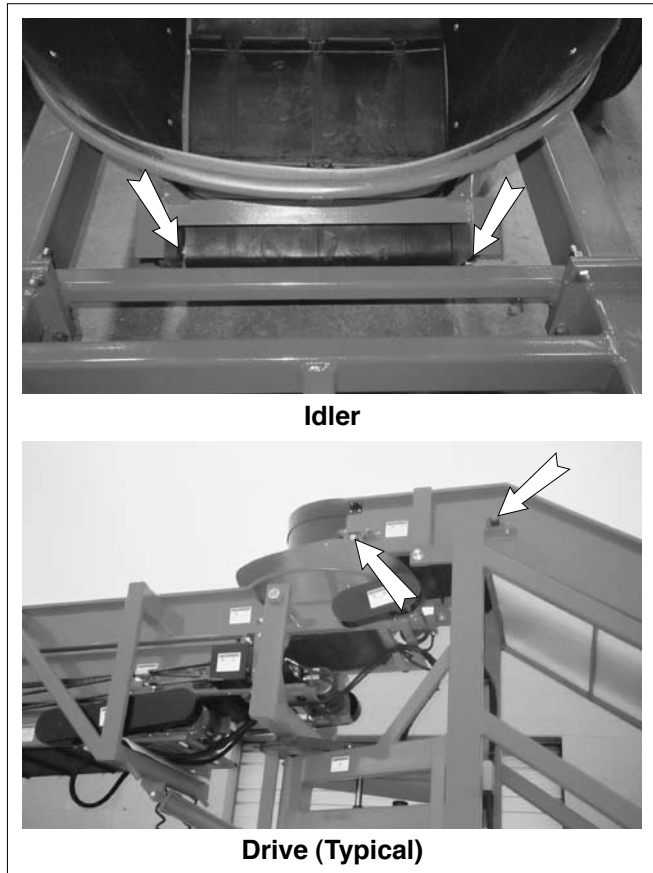

Fig. 32 ELEVATOR

b. **Boom Conveyor Shafts (Left Side):**

- Drive.
- Driven.

**IMPORTANT**

Only sealed bearings are used on the conveyor bearings. Sealed bearings should never be greased more often than weekly or every 50 hours. Do not over grease. Do not give bearing more than 1 shot of grease each time it is greased. Once the bearing seal is broken, the bearing must be greased each day or the bearing will fail.

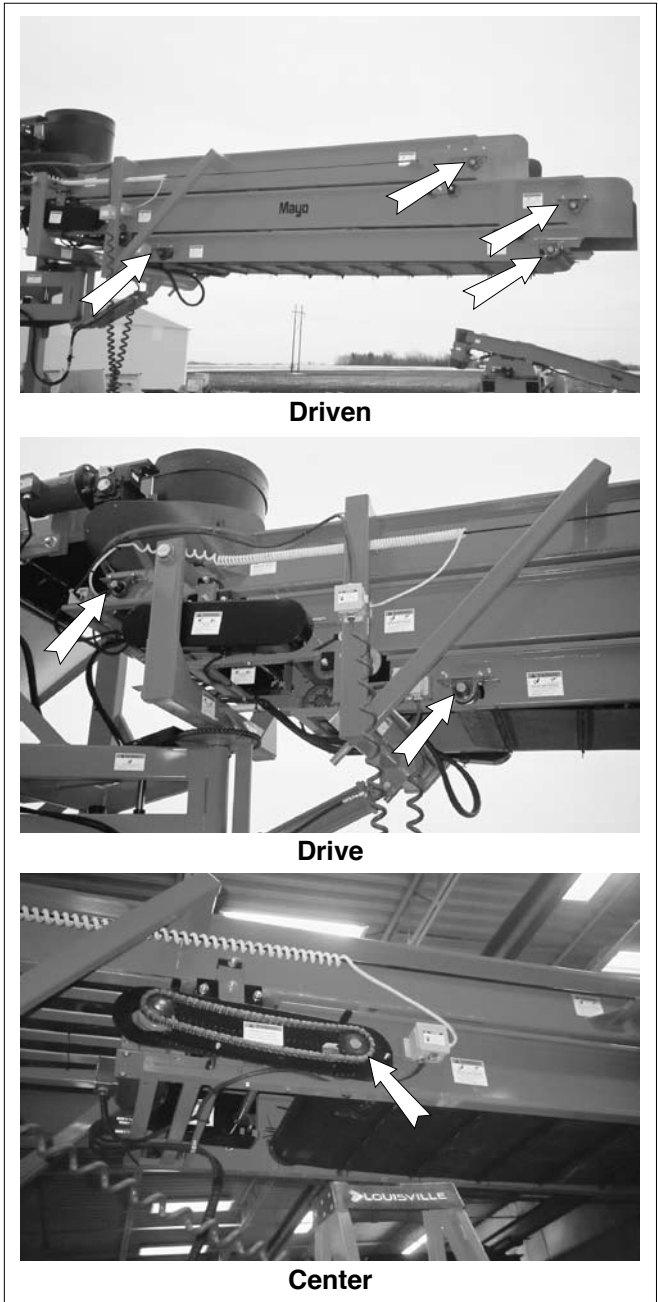

Fig. 33 CONVEYOR SHAFTS - LEFT SIDE

c. **Boom Conveyor Shafts (Right Side):**

- Drive.
- Driven.

**IMPORTANT**

Only sealed bearings are used on the conveyor bearings. Sealed bearings should never be greased more often than weekly or every 50 hours. Do not over grease. Do not give bearing more than 1 shot of grease each time it is greased. Once the bearing seal is broken, the bearing must be greased each day or the bearing will fail.

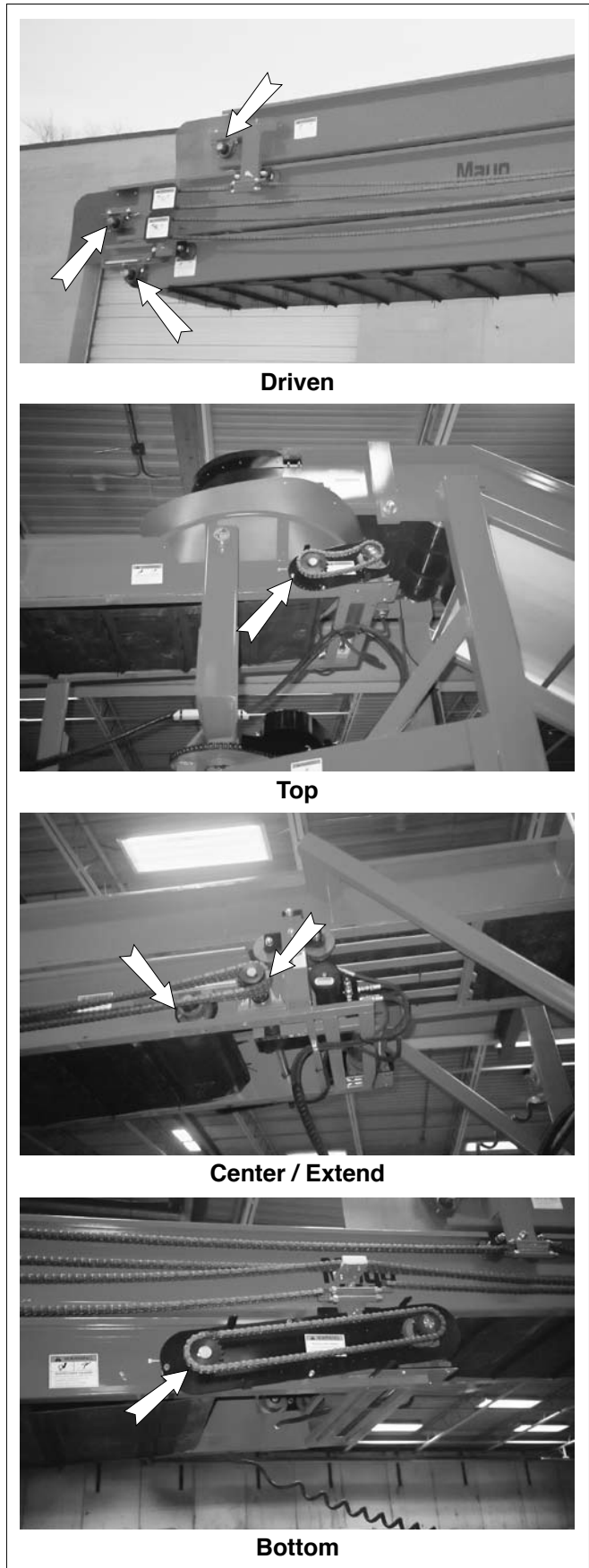
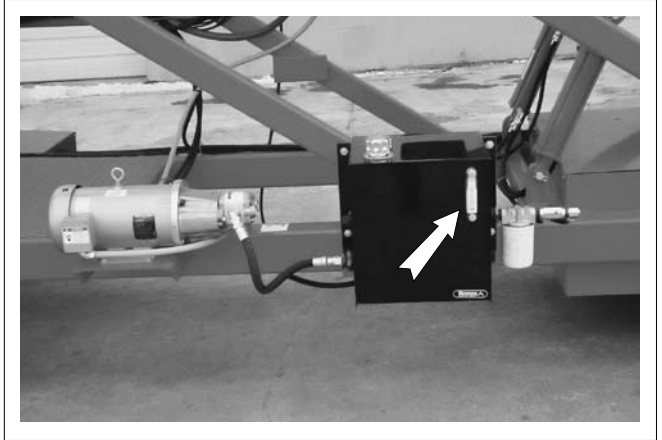

Fig. 34 CONVEYOR SHAFTS - RIGHT SIDE

2. Check oil level in hydraulic reservoir.



**Fig. 35 SIGHT GLASS**

3. Check conveyor alignment.



**Fig. 36 ELEVATOR**

4. Check roller drive chain alignment.

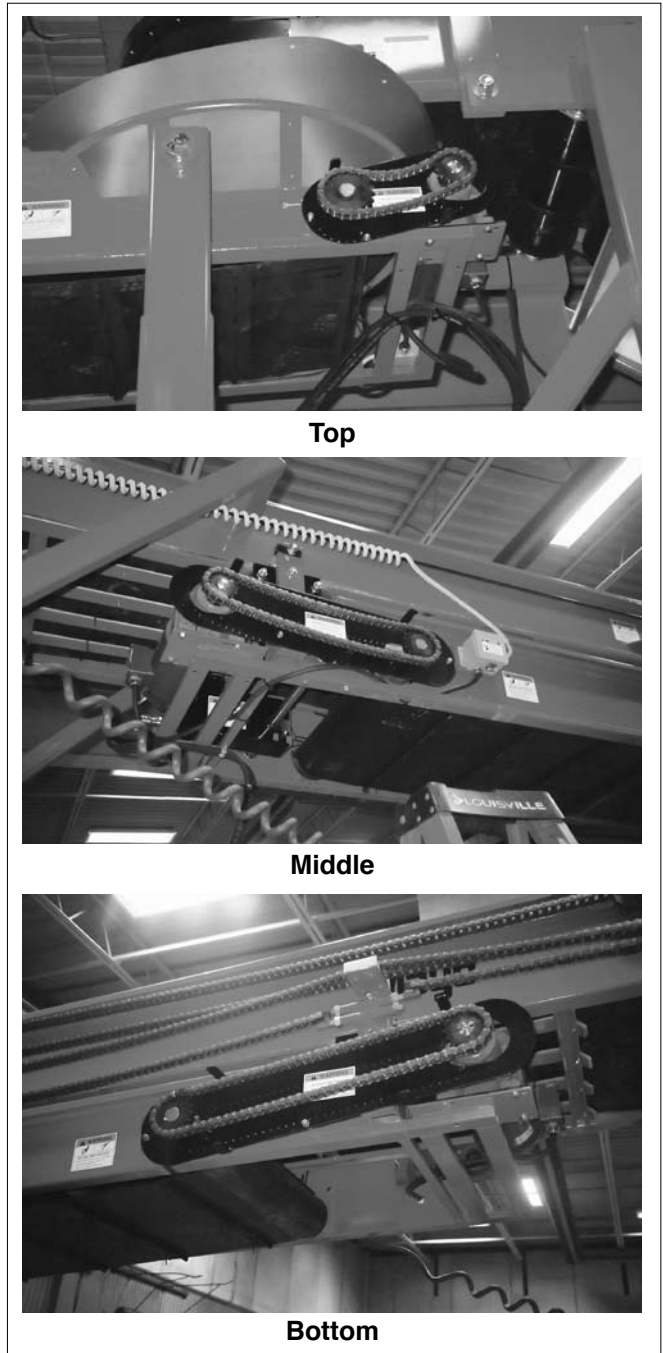

**Fig. 37 ROLLER CHAIN DRIVE**

**100 Hours or 3 Months**

1. Change hydraulic system oil filter.

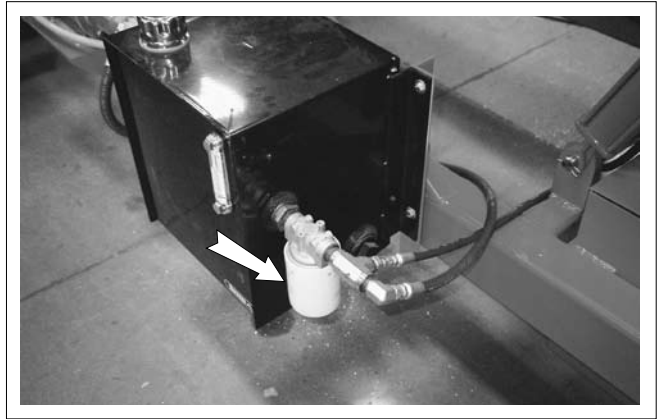

**Fig. 38 HYDRAULIC OIL FILTER**

2. Check tire pressure.



**Fig. 39 TIRE (Typical)**

**200 Hours or Annually**

1. Grease boom support shaft bushing.



**Fig. 40 BOOM SUPPORT SHAFT**



2. Grease boom swing drive shaft bearings.

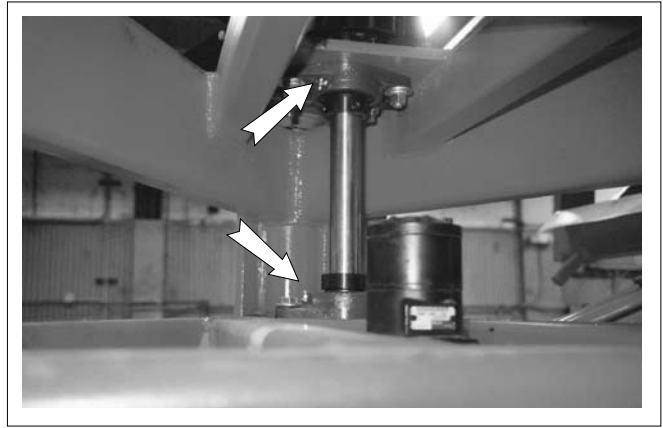

**Fig. 41 BOOM SWING DRIVE SHAFT**

3. Grease steering plates.

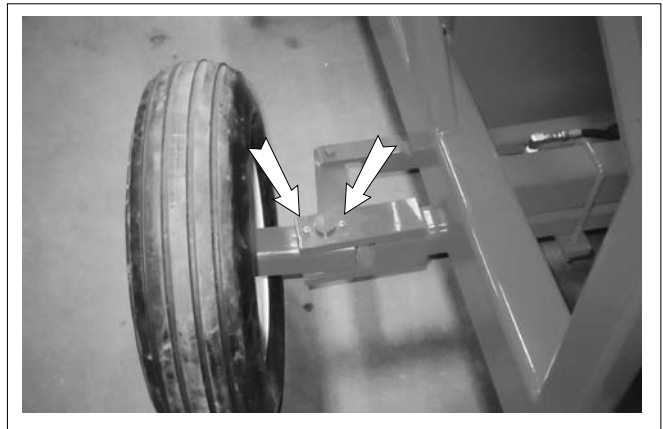

**Fig. 42 STEERING PLATE (Typical)**

4. Grease jack stands.

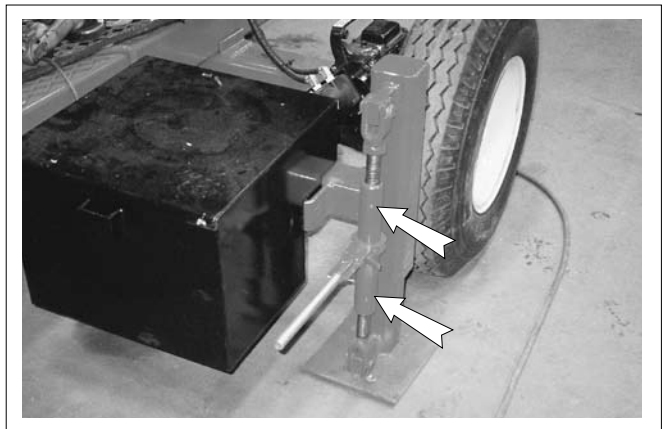

**Fig. 43 JACK STAND (Typical)**

5. Check conveyor tension.

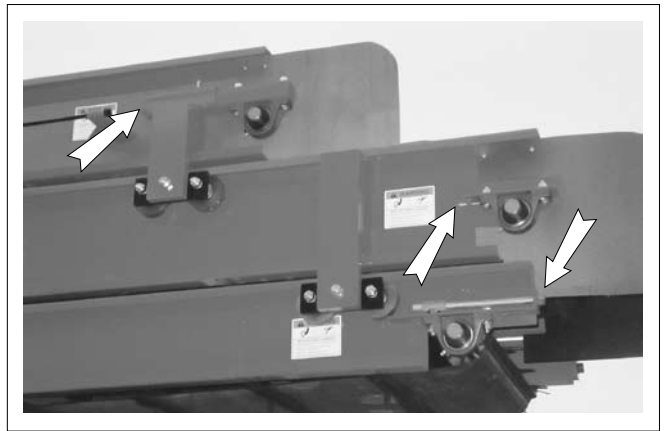

**Fig. 44 CONVEYOR TENSION**

6. Check gearbox oil levels:

a. Tractive drive.



**Tractive Drive**

b. Elevator drive.

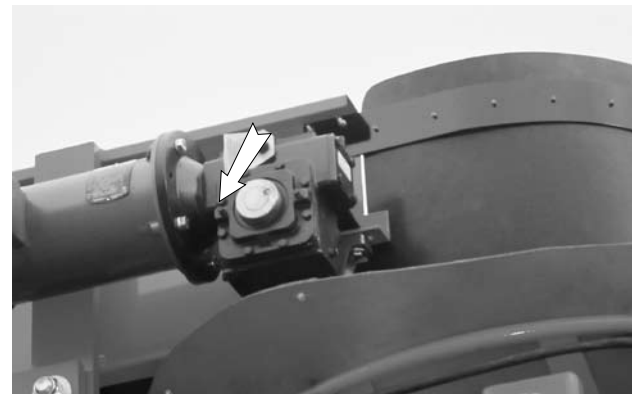

**Elevator Drive**

**Fig. 45 GEARBOX OIL LEVELS**

7. Wash machine.



**Fig. 46 MACHINE**

**Bi-Annually**

1. Change oil in hydraulic system.

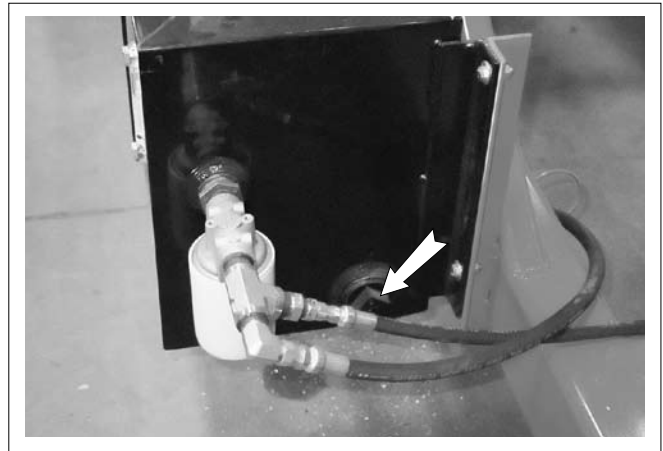

**Fig. 47 DRAIN PLUG**

### 5.1.4 SERVICE RECORD

See Lubrication and Maintenance sections for details of service. Copy this page to continue record.

ACTION CODE:     CK CHECK                     CH CHANGE                     CL CLEAN  
                           G GREASE                     RE RE-PACK

| <div style="text-align: center;"> <b>HOURS</b><br/><br/> <b>SERVICED BY</b><br/><br/> <b>MAINTENANCE</b> </div> |                                 |  |  |  |  |  |  |  |  |  |  |  |  |  |  |  |  |  |  |  |
|---|---------------------------------|--|--|--|--|--|--|--|--|--|--|--|--|--|--|--|--|--|--|--|
|   | <b>10 HOURS OR DAILY</b>        |  |  |  |  |  |  |  |  |  |  |  |  |  |  |  |  |  |  |  |
| CK  | Machine Condition               |  |  |  |  |  |  |  |  |  |  |  |  |  |  |  |  |  |  |  |
| <b>50 HOURS OR WEEKLY</b>   |                                 |  |  |  |  |  |  |  |  |  |  |  |  |  |  |  |  |  |  |  |
| G   | Conveyor Roller Bearings        |  |  |  |  |  |  |  |  |  |  |  |  |  |  |  |  |  |  |  |
| CK  | Hydraulic Oil Level             |  |  |  |  |  |  |  |  |  |  |  |  |  |  |  |  |  |  |  |
| CK  | Conveyor Alignment              |  |  |  |  |  |  |  |  |  |  |  |  |  |  |  |  |  |  |  |
| CK  | Roller Drive Chain Alignment    |  |  |  |  |  |  |  |  |  |  |  |  |  |  |  |  |  |  |  |
| <b>100 HOURS OR 3 MONTHS</b>  |                                 |  |  |  |  |  |  |  |  |  |  |  |  |  |  |  |  |  |  |  |
| CH  | Hydraulic Oil Filter            |  |  |  |  |  |  |  |  |  |  |  |  |  |  |  |  |  |  |  |
| CK  | Tire Pressure                   |  |  |  |  |  |  |  |  |  |  |  |  |  |  |  |  |  |  |  |
| <b>200 HOURS OR ANNUALLY</b>  |                                 |  |  |  |  |  |  |  |  |  |  |  |  |  |  |  |  |  |  |  |
| G   | Boom Support Shaft Bushings     |  |  |  |  |  |  |  |  |  |  |  |  |  |  |  |  |  |  |  |
| G   | Boom Swing Drive Shaft Bearings |  |  |  |  |  |  |  |  |  |  |  |  |  |  |  |  |  |  |  |
| G   | Steering Plates                 |  |  |  |  |  |  |  |  |  |  |  |  |  |  |  |  |  |  |  |
| G   | Jack Stands                     |  |  |  |  |  |  |  |  |  |  |  |  |  |  |  |  |  |  |  |
| CK  | Conveyor Belt Tension           |  |  |  |  |  |  |  |  |  |  |  |  |  |  |  |  |  |  |  |
| CK  | Gearbox Oil Levels              |  |  |  |  |  |  |  |  |  |  |  |  |  |  |  |  |  |  |  |
| CL  | Machine                         |  |  |  |  |  |  |  |  |  |  |  |  |  |  |  |  |  |  |  |
| <b>BI-ANNUALLY</b>  |                                 |  |  |  |  |  |  |  |  |  |  |  |  |  |  |  |  |  |  |  |
| CH  | Hydraulic Oil                   |  |  |  |  |  |  |  |  |  |  |  |  |  |  |  |  |  |  |  |

## 5.2 MAINTENANCE

By following a careful service and maintenance program on your machine, you will enjoy many years of trouble-free use.

### 5.2.1 CHANGING HYDRAULIC OIL AND FILTER

1. Place all controls in neutral, unplug power cord and wait for all moving parts to stop before changing oil and filter.
2. Place a pan under the drain plug.
3. Remove the drain and allow the oil to drain for 10 minutes.
4. Install and tighten the drain plug.
5. Dispose of the used oil in an approved container.
6. Remove hydraulic oil filter.
7. Apply a light coat of oil to the O ring and install the replacement filter. Snug up by hand and then tighten another 1/2 turn.
8. Fill the hydraulic oil reservoir with specified oil.
9. Plug in power cord and start hydraulic pump. Run for a couple of minutes and check hydraulic system for leaks.
10. If leaks are found around the drain plug or filter, tighten slightly. Repeat step 11.
11. Check oil level in reservoir. Top up as required.

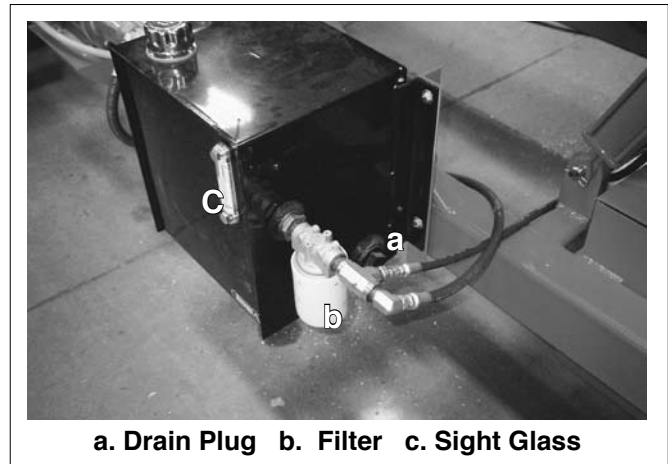

**Fig. 48 HYDRAULIC SYSTEM**

## 5.2.2 CONVEYOR BELT TENSION/ALIGNMENT OR REPLACEMENT

Conveyor belts are used to move potatoes into and through the machine. The tension and alignment of the conveyor should be checked weekly to insure proper function. Replace the conveyor belt when damaged or badly worn. To maintain conveyor belts, follow this procedure:

1. Place all controls in their OFF or neutral position.
2. Turn machine OFF, unplug power cord and lock-out tag-out.
3. **Tension:**  
The belts are tensioned correctly when they do not sag below the conveyor frame.



Fig. 49 CONVEYOR FRAMES

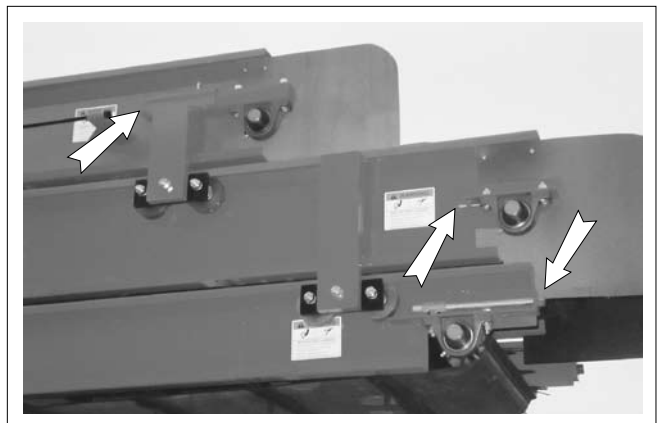

Fig. 50 TENSION ADJUSTING (Typical)

4. **Alignment:**

The conveyors are properly aligned when the belt runs in the center of the frame panels and the shafts. Be sure to run the conveyor a full revolution to check the entire belt. The belt can move from side-to-side while it is turning as long as it doesn't contact the sides. If it contacts the sides, it must be aligned. Align by loosening the shaft bearing assembly on the tight side or tightening the bearing assembly on the loose side. Move the bearing assemblies on the driven shaft to align the conveyor but always maintain the proper tension.

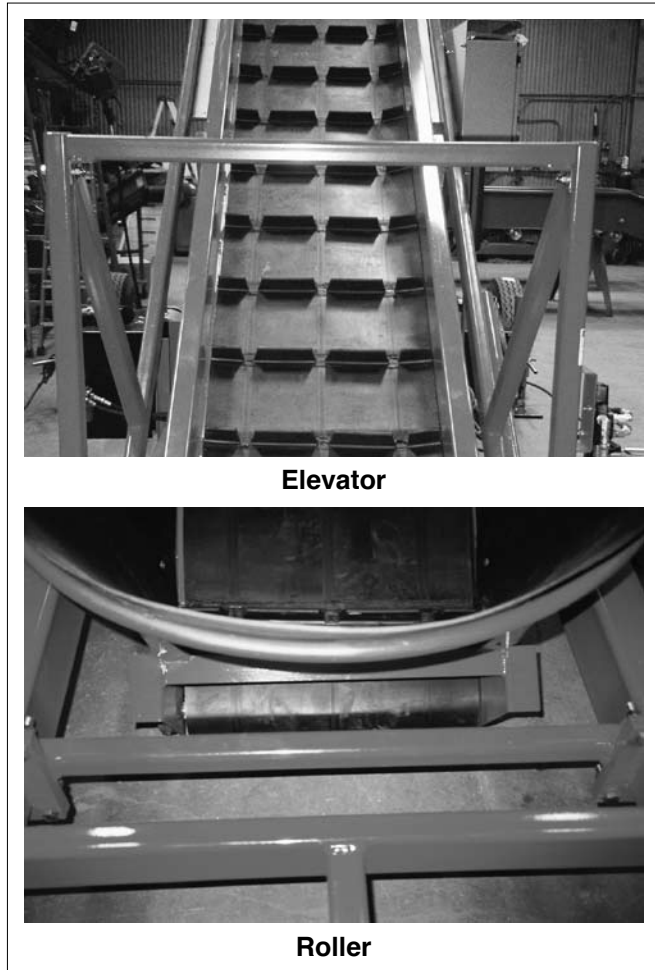

Fig. 51 BELT ALIGNMENT

5. **Replacement:**

- a. Move one or both of the shafts into their loosest position.
- b. Open the belt by removing the connecting rod on the belt.
- c. Attach the replacement belt to the end of the old belt.
- d. Slowly pull the old belt out of the machine and thread the new one into position.
- e. Disconnect the old belt and connect the ends of the new one together.
- f. Move the shaft into position to set the tension of the belt and secure the bearing assemblies.
- g. Check the tension and alignment of the belt frequently during the first 10 hours of operation and set as required. Then, go to the regular maintenance schedule. Normally a belt will seat itself during the first 10 hours of operation and then require less adjustment.

### 5.2.3 CONVEYOR DRIVE ROLLER CHAIN TENSION

All boom conveyors are driven by electric motors into a speed reducing gearbox through a roller chain. The tension and alignment of each roller chain should be checked weekly to insure proper function. Replace the roller chain when damaged or badly worn.

To maintain roller chain, follow this procedure:

1. Clear the area of bystanders, especially small children.
2. Place all controls in their OFF or neutral position, unplug power cord and lock-out tag-out.
3. Remove guards covering drives.



4. **Tension:**  
Each chain needs to have some sag to it in order to be properly tensioned.

- a. Loosen gearbox mounting bolts.
- b. Slide or tap gearbox into its required position.

**NOTE**

Do not over-tighten roller chain. A chain that is too tight will wear rapidly.

- c. Tighten gearbox mounting bolts.

**NOTE**

Be sure sprockets are aligned.

- d. Install and secure all guards.

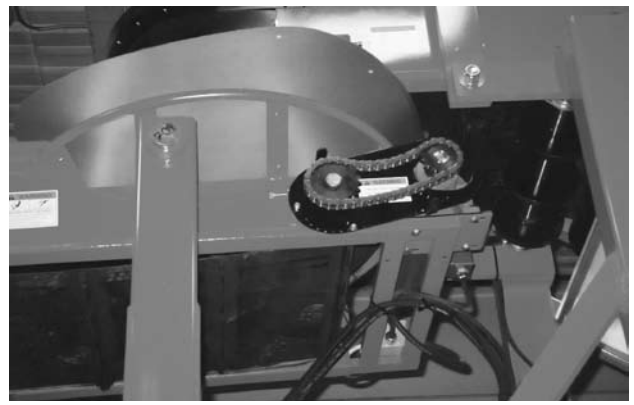

**Top**

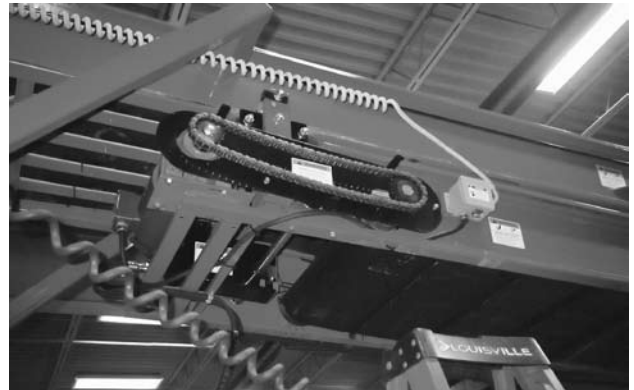

**Middle**



**Bottom**

**Fig. 52 ROLLER CHAIN DRIVE**



# 6 TROUBLESHOOTING

The Mayo Rail Car Loader is a telescoping and swinging conveyor that is used to load potatoes into a rail car. It is a simple and reliable system that requires minimum maintenance.

In the following section, we have listed many of the problems, causes and solutions to the problems that you may encounter.

If you encounter a problem that is difficult to solve, even after having read through this trouble shooting section, please contact your local Mayo dealer or the factory. Before you call, please have this Operator's Manual and the serial number from your machine ready.

| <b>PROBLEM</b>                        | <b>CAUSE</b>                  | <b>SOLUTION</b>                                     |
|---------------------------------------|-------------------------------|---|
| Conveyors won't run.                  | No power.                     | Plug in power cord.                                 |
|                                       | Emergency stop switch off.    | Make sure all emergency stop switches are released. |
|                                       | Wrong setting for remote.     | Turn switch on master control panel to "remote".    |
| <hr/>                                 |                               |   |
| Conveyors won't move.                 | Drive system disengaged.      | Engage drive system.                                |
| <hr/>                                 |                               |   |
| Boom telescopes too fast or too slow. | Wrong system speed setting.   | Adjust system speed valve.                          |
| <hr/>                                 |                               |   |
| Boom raises/lowers too fast/slow.     | Wrong vertical speed setting. | Adjust needle valve setting.                        |

## **7 SPECIFICATIONS**

### **7.1 MECHANICAL**

**SPECIFICATIONS SUBJECT TO CHANGE WITHOUT NOTICE**

## 7.2 BOLT TORQUE

### CHECKING BOLT TORQUE

The tables shown below give correct torque values for various bolts and capscrews. Tighten all bolts to the torques specified in chart unless otherwise noted. Check tightness of bolts periodically, using bolt torque chart as a guide. Replace hardware with the same strength bolt.

### ENGLISH TORQUE SPECIFICATIONS

| Bolt Diameter "A" | Bolt Torque*           |     |                        |     |                        |     |
|-------------------|------------------------|-----|------------------------|-----|------------------------|-----|
|                   | SAE 2<br>(N.m) (lb-ft) |     | SAE 5<br>(N.m) (lb-ft) |     | SAE 8<br>(N.m) (lb-ft) |     |
| 1/4"              | 8                      | 6   | 12                     | 9   | 17                     | 12  |
| 5/16"             | 13                     | 10  | 25                     | 19  | 36                     | 27  |
| 3/8"              | 27                     | 20  | 45                     | 33  | 63                     | 45  |
| 7/16"             | 41                     | 30  | 72                     | 53  | 100                    | 75  |
| 1/2"              | 61                     | 45  | 110                    | 80  | 155                    | 115 |
| 9/16"             | 95                     | 60  | 155                    | 115 | 220                    | 165 |
| 5/8"              | 128                    | 95  | 215                    | 160 | 305                    | 220 |
| 3/4"              | 225                    | 165 | 390                    | 290 | 540                    | 400 |
| 7/8"              | 230                    | 170 | 570                    | 420 | 880                    | 650 |
| 1"                | 345                    | 225 | 850                    | 630 | 1320                   | 970 |

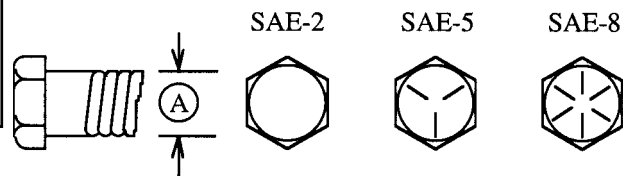

### METRIC TORQUE SPECIFICATIONS

| Bolt Diameter "A" | Bolt Torque*         |      |                       |      |
|-------------------|----------------------|------|-----------------------|------|
|                   | 8.8<br>(N.m) (lb-ft) |      | 10.9<br>(N.m) (lb-ft) |      |
| M3                | .5                   | .4   | 1.8                   | 1.3  |
| M4                | 3                    | 2.2  | 4.5                   | 3.3  |
| M5                | 6                    | 4    | 9                     | 7    |
| M6                | 10                   | 7    | 15                    | 11   |
| M8                | 25                   | 18   | 35                    | 26   |
| M10               | 50                   | 37   | 70                    | 52   |
| M12               | 90                   | 66   | 125                   | 92   |
| M14               | 140                  | 103  | 200                   | 148  |
| M16               | 225                  | 166  | 310                   | 229  |
| M20               | 435                  | 321  | 610                   | 450  |
| M24               | 750                  | 553  | 1050                  | 774  |
| M30               | 1495                 | 1103 | 575                   | 1550 |
| M36               | 2600                 | 1917 | 3675                  | 2710 |

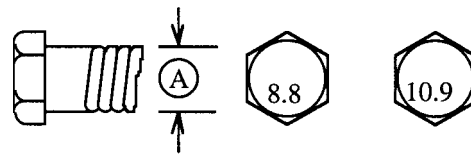

Torque figures indicated above are valid for non-greased or non-oiled threads and heads unless otherwise specified. Therefore, do not grease or oil bolts or capscrews unless otherwise specified in this manual. When using locking elements, increase torque values by 5%.

\* Torque value for bolts and capscrews are identified by their head markings.

## 7.3 LUBRICANT SPECIFICATIONS

| <b>MAYO MFG. RECOMMENDS THE FOLLOWING MOBIL PRODUCTS OR THEIR EQUIVALENTS</b> |                               |   |                                      |   |
|---|-------------------------------|---|--------------------------------------|---|
| Lubricant Type  | Component                     | Specification                             | Recommended Lubricant                | Recommended Temperature/ Service Interval         |
| Hydraulic Oil   | Hydraulic Reservoir           | ISO 32, Synthetic Food Grade, NSF-H1      | Mobil SHC Cibus 32                   | All Temperatures/Oil sample guidance or 12 months |
|   | Hydraulic Reservoir           | ISO 32, Food Grade, NSF-H1                | Mobil DTE FM 32                      | 10F to 140F/Oil sample guidance or 12 months      |
| Grease  | Greased Bearings/ Points      | Food Grade                                | Mobilgrease FM 222                   | All/Weekly or as needed                           |
|   | Greased Bearings/ Points      | Non-Food                                  | Mobilgrease XHP 222                  |   |
| Gear Oil  | Winsmith Worm Gear Reducer    | Poly Alkylene Glycol (PAG) ISO 460 NSF H1 | Mobil Glygoyle 460                   | All/See Manual<br>Note: Do Not Substitute         |
|   | Browning Helical Gear Reducer | Synthetic, PAO Type ISO 220 NSF H1        | Mobil SHC 630 or Mobil SHC Cibus 220 | All/Change Every Two Years                        |
|   | Auburn Planetary Wheel Drives | SAE GL-5 75w90                            | Mobil Delvac Synthetic 75w90         | All/Change Every Two Years                        |

**\*\*FOR SAFETY, ALWAYS LOCKOUT & TAGOUT\*\***

## 7.4 HYDRAULIC FITTING TORQUE

### Tightening Flare Type Tube Fittings \*

1. Check flare and flare seat for defects that might cause leakage.
2. Align tube with fitting before tightening.
3. Lubricate connection and hand tighten swivel nut until snug.
4. To prevent twisting the tube(s), use two wrenches. Place one wrench on the connector body and with the second tighten the swivel nut to the torque shown.

| Tube Size OD | Nut Size Across Flats | Torque Value* |           | Recommended Turns To Tighten (After Finger Tightening) |            |
|--------------|-----------------------|---------------|-----------|--|------------|
|              |                       | (N.m)         | (lb-ft)   | (Flats)  | (Turn)     |
| 3/16         | 7/16                  | 8             | 6         | 1  | 1/6        |
| 1/4          | 9/16                  | 12            | 9         | 1  | 1/6        |
| 5/16         | 5/8                   | 16            | 12        | 1  | 1/6        |
| <b>3/8</b>   | <b>11/16</b>          | <b>24</b>     | <b>18</b> | <b>1</b>   | <b>1/6</b> |
| 1/2          | 7/8                   | 46            | 34        | 1  | 1/6        |
| 5/8          | 1                     | 62            | 46        | 1  | 1/6        |
| 3/4          | 1-1/4                 | 102           | 75        | 3/4  | 1/8        |
| 7/8          | 1-3/8                 | 122           | 90        | 3/4  | 1/8        |

- The torque values shown are based on lubricated connections as in reassembly.

# 8 INDEX

|                                    | PAGE |  | PAGE |
|------------------------------------|------|--|------|
| <b>I</b>                           |      |  |      |
| Introduction.....                  | 1    |  |      |
| Index.....                         | 56   |  |      |
| <b>O</b>                           |      |  |      |
| Operation.....                     | 15   |  |      |
| Controls .....                     | 19   |  |      |
| General Operation Theory.....      | 17   |  |      |
| Machine Break-In .....             | 18   |  |      |
| Machine Components.....            | 16   |  |      |
| Operating.....                     | 24   |  |      |
| Pre-Operation Checklist .....      | 18   |  |      |
| Storage .....                      | 33   |  |      |
| To The New Operator or Owner ..... | 15   |  |      |
| Transport .....                    | 35   |  |      |
| <b>S</b>                           |      |  |      |
| Safety .....                       | 2    |  |      |
| Employee Sign-Off Form .....       | 9    |  |      |
| Equipment Safety Guidelines .....  | 4    |  |      |
| General Safety.....                | 3    |  |      |
| Hydraulic Safety .....             | 4    |  |      |
| Installation Safety .....          | 6    |  |      |
| Lock-Out Tag-Out Safety .....      | 8    |  |      |
| Maintenance Safety.....            | 8    |  |      |
| Operating Safety.....              | 7    |  |      |
| Preparation .....                  | 6    |  |      |
| Safety Signs .....                 | 5    |  |      |
| Safety Training.....               | 5    |  |      |
| Storage Safety.....                | 8    |  |      |
| Transport Safety .....             | 7    |  |      |
| Tire Safety .....                  | 8    |  |      |
| Safety Sign Locations.....         | 10   |  |      |
| Service and Maintenance .....      | 37   |  |      |
| Maintenance .....                  | 48   |  |      |
| Service.....                       | 37   |  |      |
| Specifications .....               | 53   |  |      |
| Bolt Torque .....                  | 54   |  |      |
| Hydraulic Fitting Torque.....      | 55   |  |      |
| Lubrication .....                  | 55   |  |      |
| Mechanical .....                   | 53   |  |      |
| <b>T</b>                           |      |  |      |
| Trouble Shooting .....             | 52   |  |      |

# **MAYO MANUFACTURING CO.**

**BUS HIGHWAY 2 BOX 497  
EAST GRAND FORKS, MN 56721**

**PHONE (218) 773-1234  
TOLL FREE (800) 223-5873  
FAX (218) 773-6693**